



PRODUCT RANGE

SCREENS & CONVEYORS

2021



XAVA[®]
recycling
SCREENS & MORE



XAVA Vibrating Screens and Conveyor Belts 2021

www.xava-recycling.at

OVERVIEW

VIBRATING SCREEN LS12	06
VIBRATING SCREEN LS14	08
VIBRATING SCREEN LS14X	10
VIBRATING SCREEN LS24	12
VIBRATING SCREEN LS28	14
OPTIONS VIBRATING SCREENS	16
XAVA INDIVIDUAL	17
CONVEYOR BELTS	18



OUR PHILOSOPHY

SCREENS & MORE!

XAVA's "Screens & More" philosophy is clearly demonstrated by our compact screening solutions for cost-effective, efficient and environmentally-friendly recycling.

XAVA screens are suitable for processing many different kinds of material and can be used by construction, demolition or recycling companies, composters, municipalities or even by private home builders. With a XAVA screen, there is no need to hire expensive commercial service providers to recycle material, nor does the material have to be transported and disposed of at great cost.

The major value of XAVA's range of screens is the ability to screen and recycle the material at any time, in any place, to return it back into the raw material cycle.

Cost-Effective Screening The Easy Way is the motto!

Because purchase price and operating costs are low, XAVA machines offer an extremely favourable return on investment. Very little maintenance is needed, handling is uncomplicated and the machines also have a low impact on the environment.

ABOUT US

XAVA Recycling specializes in the production and distribution of compact, robust and environmentally friendly screens and conveyors.

XAVA machines are very versatile and can screen any kind of material such as soil, compost, gravel, demolition waste, slag, wood chips, etc. The set-up of each screen for the various applications is coordinated with the experienced XAVA team and its sales partners, so the highest possible quality can be guaranteed.

The easy transport, the rapid set-up and the intuitive operation enable customers to immediately start working efficiently with a XAVA screen.

We are 100% convinced of the durability and the high quality of all XAVA machines and offer **2 YEARS WARRANTY** on every new XAVA screen. In the event of a defect during the warranty period, it will be quickly repaired by a specialist from XAVA headquarters or one of our qualified distributors **WITHOUT additional charges.**

Fast and reliable availability of all XAVA machines is a top priority for XAVA Recycling.

Stefan Löbl, CEO





VIBRATING SCREEN LS12

TECHNICAL DATA

Weight:	190 kg
Vibro motor:	0.16 kW, 1,500 rpm
Connection:	230 V with IP54 protection
Installation area:	1,180 mm x 1,210 mm
Height:	1,440 mm
Screen size:	1,040 x 675 mm

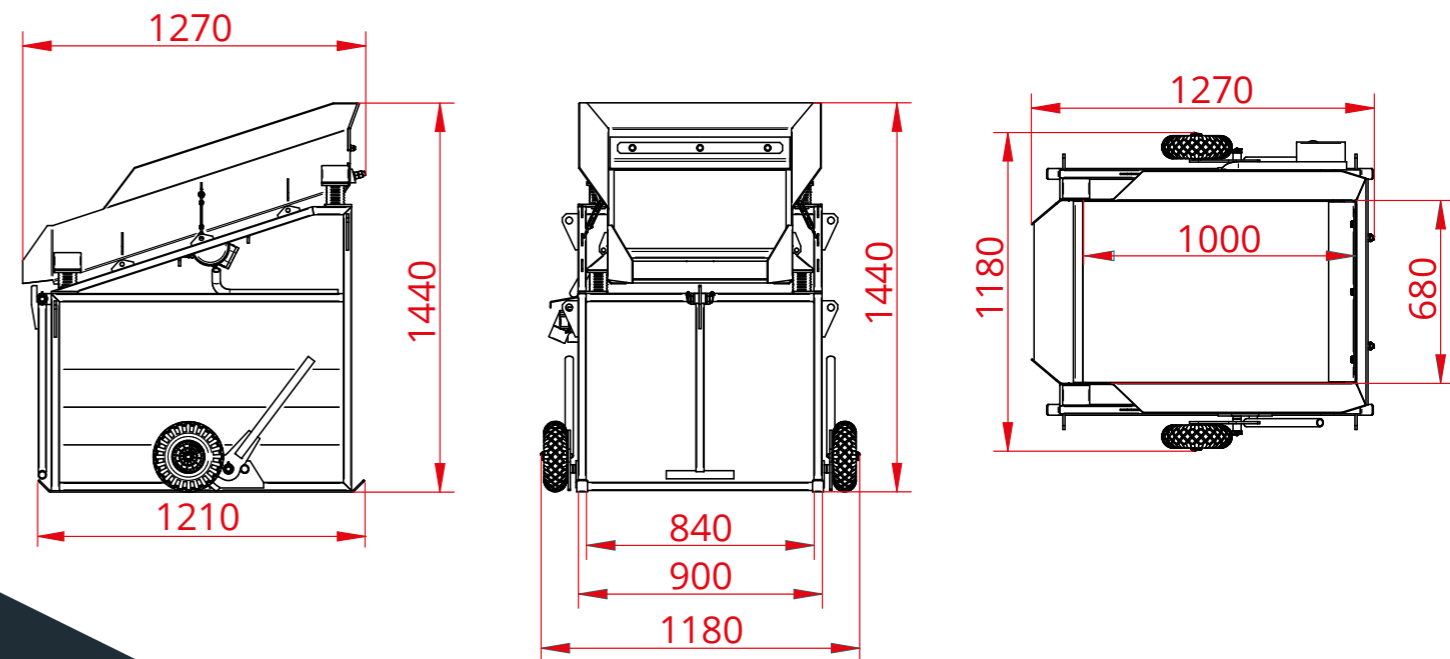

EASY & COMPACT

- ✓ **SIMPLE OPERATION** - Standard 230V socket connection
- ✓ **CLEAN** - Purely electric drive, no site contamination due to damaged hydraulic lines or similar
- ✓ **FLEXIBLE** - Separation of various materials thanks to the use of different screen meshes
- ✓ **LOW WEIGHT** - Very easy manoeuvring thanks to LIFT & MOVE system
- ✓ **LOW MAINTENANCE** - Bolts must be checked, sealed bearings on the vibration motor
- ✓ **STUDED TYRES** - Provide better traction on every surface



APPLICATIONS

COMPOST ♦ SOIL ♦ GRAVEL ♦ SAND ♦ CONSTRUCTION WASTE ♦ WOOD ♦ BRICKS ♦ BARK MULCH ♦ STONES ♦ WOOD CHIPS ♦ ASPHALT





VIBRATING SCREEN LS14

TECHNICAL DATA

Weight:	300 kg incl. lifting device
Vibro motor:	0.4 kW, 1,500 rpm
Connection:	230 V with IP54 protection
Installation area:	1,310 mm x 1,210 mm
Height:	1,440 mm
Screen size:	1,080 x 1,040 mm

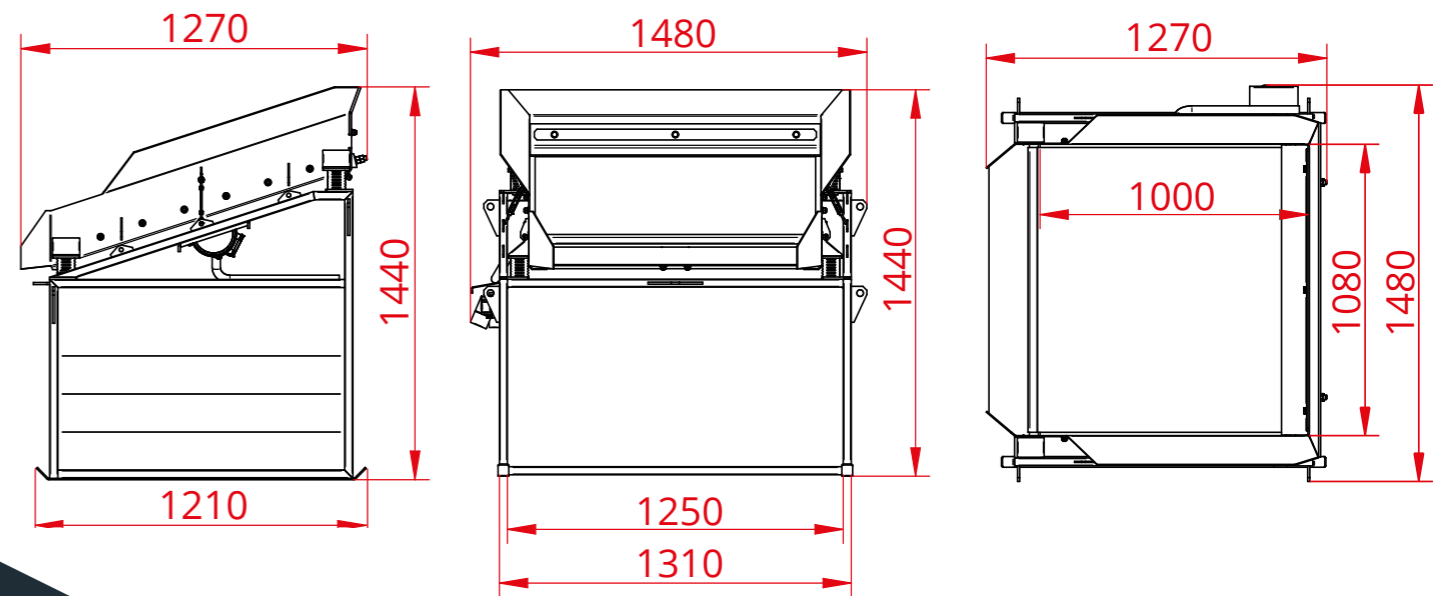

DURABLE & VERSATILE

- ✓ **SIMPLE OPERATION** - Standard 230V socket connection
- ✓ **CLEAN** - Purely electric drive, no site contamination due to damaged hydraulic lines or similar
- ✓ **FLEXIBLE** - Separation of various materials thanks to the use of different screen meshes
- ✓ **FAST MANOEUVRING** - by means of a lifting device or chains
- ✓ **LOW MAINTENANCE** - Bolts must be checked, sealed bearings on the vibration motor
- ✓ **EASY TRANSPORT** - thanks to its low weight - fits on a standard car trailer



APPLICATIONS

COMPOST ♦ SOIL ♦ GRAVEL ♦ SAND ♦ CONSTRUCTION WASTE ♦ WOOD ♦ BRICKS ♦ BARK MULCH ♦ STONES ♦ WOOD CHIPS ♦ ASPHALT





VIBRATING SCREEN LS14X

TECHNICAL DATA

Weight:	370 kg incl. lifting device
Vibro motor:	0.4 kW, 1,500 rpm
Connection:	230 V with IP54 protection
Installation area:	1,510 mm x 1,210 mm
Height:	1,900 mm
Screen size:	1,080 x 1,040 mm

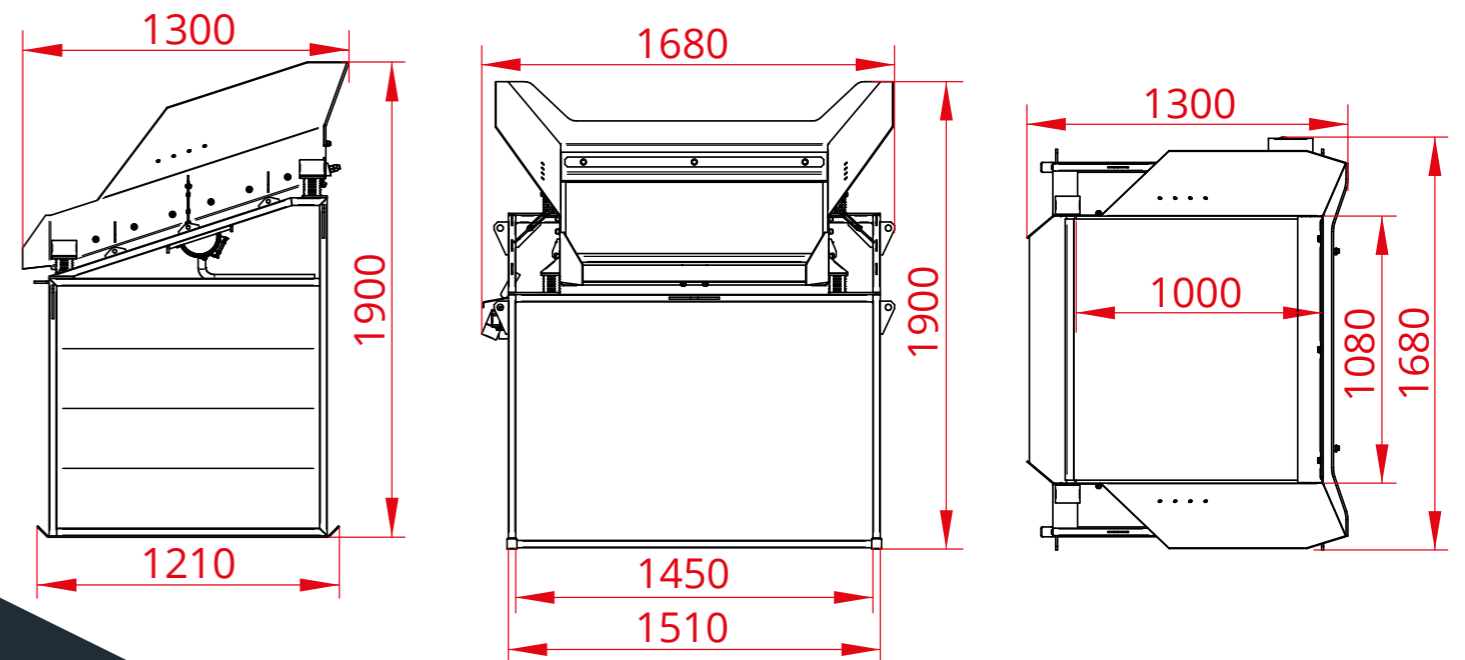

EFFICIENT & UNIVERSAL

- ✓ **SIMPLE OPERATION** - Standard 230V socket connection
- ✓ **CLEAN** - Purely electric drive, no site contamination due to damaged hydraulic lines or similar
- ✓ **FLEXIBLE** - Separation of various materials thanks to the use of different screen meshes
- ✓ **FAST MANOEUVRING** - by means of a lifting device or chains
- ✓ **LOW MAINTENANCE** - Bolts must be checked, sealed bearings on the vibration motor
- ✓ **EASY TRANSPORT** - thanks to its low weight - fits on a standard car trailer



APPLICATIONS

COMPOST ♦ SOIL ♦ GRAVEL ♦ SAND ♦ CONSTRUCTION WASTE ♦ WOOD ♦ BRICKS ♦ BARK MULCH ♦ STONES ♦ WOOD CHIPS ♦ ASPHALT





7.11 M² SCREEN SURFACE!

VIBRATING SCREEN LS24

TECHNICAL DATA

Weight:	1,400 kg incl. lifting device	Screen top deck:	2 units 1,630 x 1,090 mm
Vibro motor:	1.15 kW, 1,500 rpm	Screen lower deck:	2 units 1,630 x 1,090 mm
Connection:	380 V, 50 Hz, 16 A with IP3X protection with operating hours counter	*2-deck screen container for 3 fractions set-up:	
Height:	2,290 mm	Top deck - discharge side front left	
Installation area:	2,400 mm x 1,580 mm	Lower deck - discharge side front right	
Screen sizes:	2 x 2,180 x 1,630 mm	Fine material - discharge into the container	

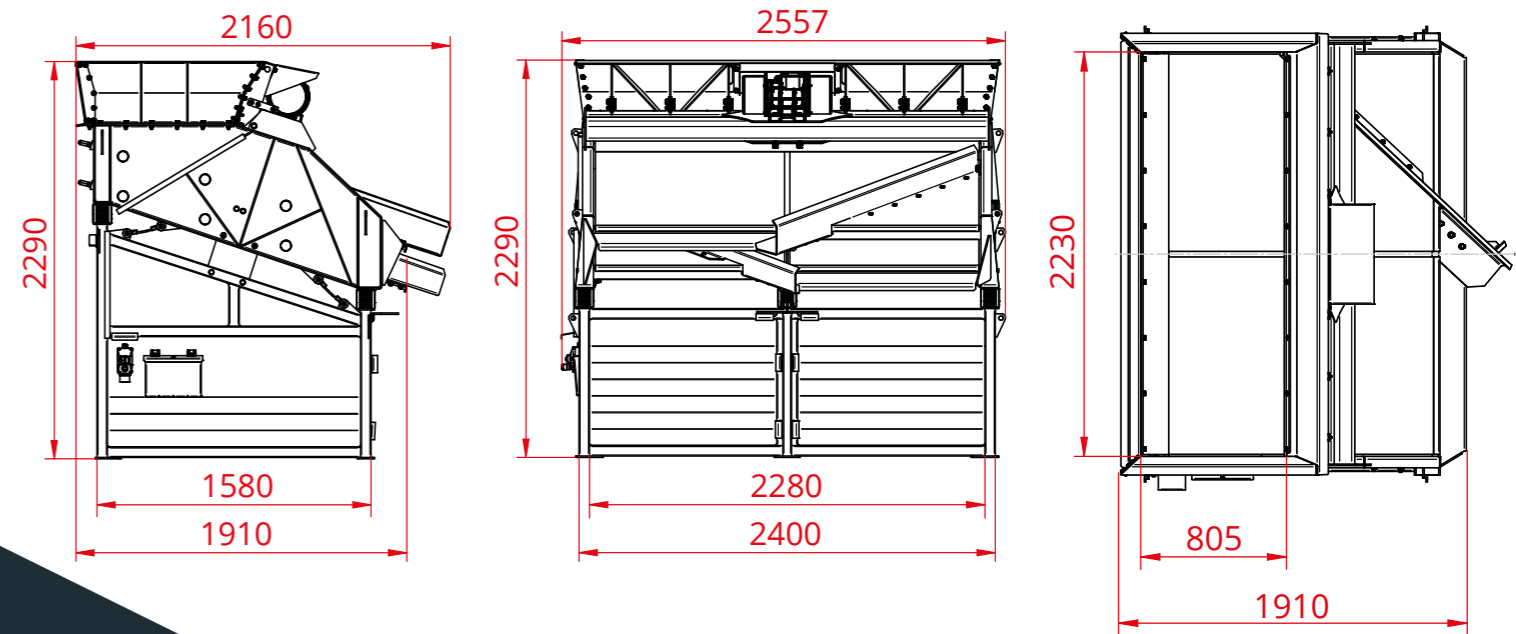

ROBUST & FLEXIBLE

- SIMPLE OPERATION** - Connection to 16A high voltage current
- CLEAN** - Purely electric drive, no site contamination due to damaged hydraulic lines or similar
- FLEXIBLE** - Separation of various materials thanks to the use of different screen meshes
- UP TO 3 FRACTIONS** - with removable discharge chutes and separation plate
- LOW MAINTENANCE** - Screws must be checked, maintenance-free bearings on the vibration motor
- EASY TRANSPORT** - with a standard car trailer, easy manoeuvring by means of an included lifting device



APPLICATIONS

COMPOST ♦ SOIL ♦ GRAVEL ♦ SAND ♦ CONSTRUCTION WASTE ♦ WOOD ♦ BRICKS ♦ BARK MULCH ♦ STONES ♦ WOOD CHIPS ♦ ASPHALT

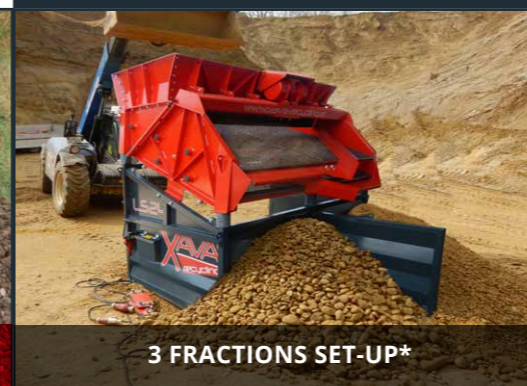

3 FRACTIONS SET-UP*

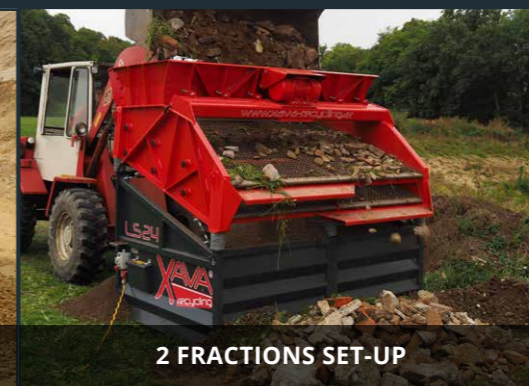

2 FRACTIONS SET-UP





8.35 m² SCREEN SURFACE!

VIBRATING SCREEN LS28

TECHNICAL DATA

Weight:	1,700 kg incl. lifting device	Screen top deck:	2 units 1,630 x 1,280 mm
Vibro motor:	1.15 kW, 1,500 rpm	Screen lower deck:	2 units 1,630 x 1,280 mm
Connection:	380 V, 50 Hz, 16 A with IP3X protection with operating hours counter	*2-deck screen container for 3 fractions set-up:	
Height:	2,541 mm	Top deck - discharge side front left	
Installation area:	2,800 mm x 1,600 mm	Lower deck - discharge side front right	
Screen size:	2 x 2,560 x 1,630 mm	Fine material - discharge into the container	

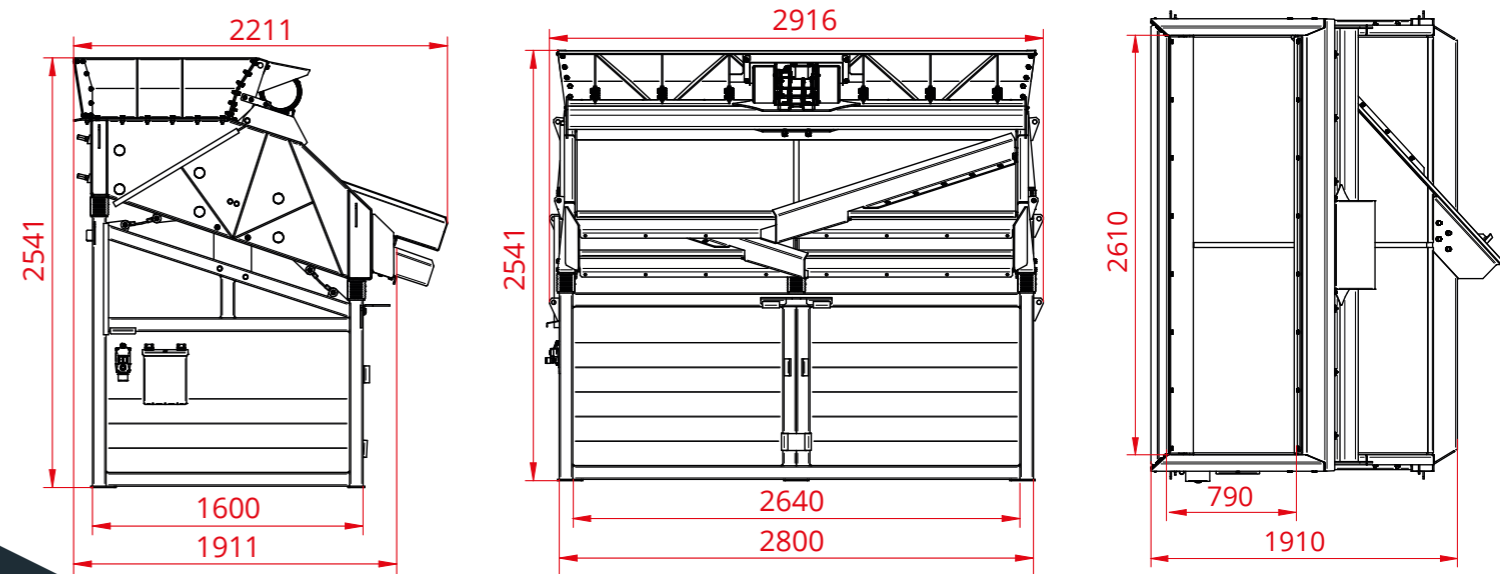

SIMPLE & FUNCTIONAL

- ✓ **SIMPLE OPERATION** - Connection to 16A high voltage current
- ✓ **CLEAN** - Purely electric drive, no site contamination due to damaged hydraulic lines or similar
- ✓ **FLEXIBLE** - Separation of various materials thanks to the use of different screen meshes
- ✓ **UP TO 3 FRACTIONS** - with removable discharge chutes and separation plate
- ✓ **LOW MAINTENANCE** - Bolts must be checked, sealed bearings on the vibration motor
- ✓ **EASY TRANSPORT** - with a standard car trailer, easy manoeuvring by means of an included lifting device



APPLICATIONS

COMPOST ♦ SOIL ♦ GRAVEL ♦ SAND ♦ CONSTRUCTION WASTE ♦ WOOD ♦ BRICKS ♦ BARK MULCH ♦ STONES ♦ WOOD CHIPS ♦ ASPHALT

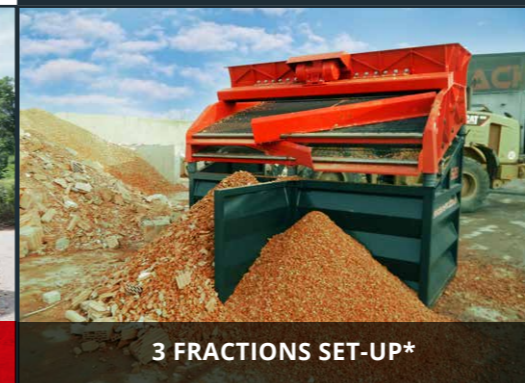

3 FRACTIONS SET-UP*



2 FRACTIONS SET-UP



OPTIONS VIBRATING SCREENS



WATER SPRAYING

For dust suppression or washing all kinds of materials such as gravel, crushed stone, etc. Supply via a standard water connection.

Available for all XAVA vibrating screens.



METERING PLATE

for LS24 und LS28.

For better dosage of various materials such as wood chips, sand, gravel etc. instead of the standard squeegee rubber.



S-LINE

For stationary use of the LS24 and LS28 screening machines.

Use for instance for a fixed installation in a recycling process or for placement on concrete foundations etc.



3 FRACTIONS SET-UP

for LS24 and LS28.

Thanks to the simple attachment of the deviation and separating plates, various materials can be screened in 3 fractions in a very short time.

XAVA INDIVIDUAL

LOOKING FOR A CUSTOM-BUILT SCREEN?

XAVA plans, designs and builds custom screens for a variety of applications.

Due to the modular design of XAVA machines, customer-specific modifications can easily be implemented.

Get in touch with us and together we will design the perfect screen, engineered and manufactured to meet your precise requirements.

XAVA INDIVIDUAL - Your partner for special screening projects.

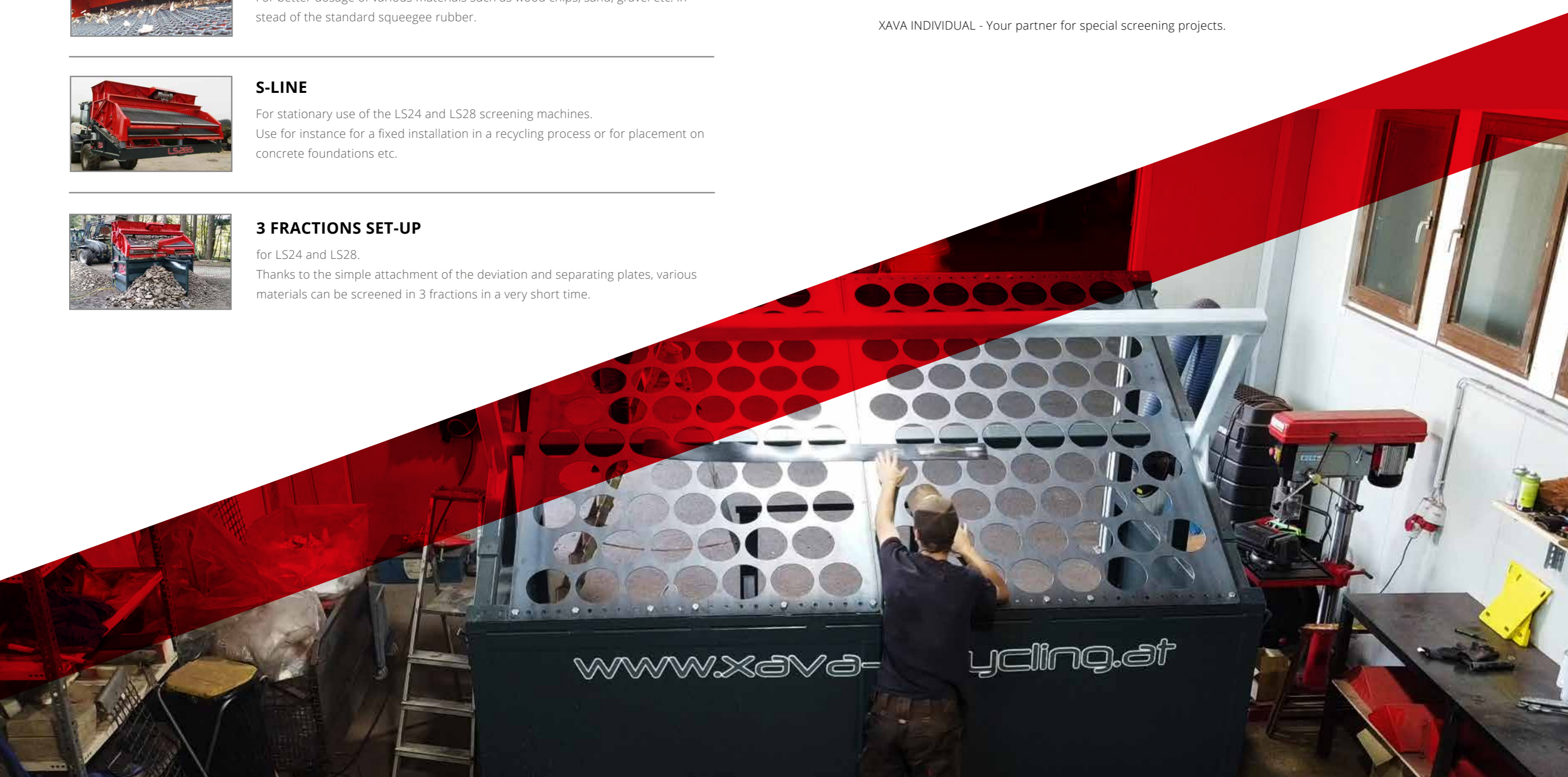



Conveyor Belts 2.5-6 m

UNIVERSAL APPLICATIONS

- Heavy duty conveyor belt with easy belt adjustment, various belt types available

Electrical components installed safely and securely

Low weight thanks to aluminium construction, stackable

Removable chassis and removable and movable hopper
- Very quick and easy maintenance and cleaning

Forklift truck mounting bracket and closed side profile

High loading capacity, extremely resilient during loading and operation

FORWARD AND REVERSE RUNNING, VARIABLE SPEEDS AND SERIES CONNECTION!

TECHNICAL DATA

	CU2500	CU3000	CU4500	CU6000
BELT LENGTHS (CM)	250	300	450	600
TOTAL LENGTHS (CM)	280	360	480	630
BELT WIDTH (CM)	34	34	34	34
TOTAL WIDTH (CM)	45.5	45.5	45.5	45.5
HEIGHT (CM)	25	25	25	25
WEIGHT (KG)	61	71	87	103
DRUM MOTOR (kW)	0.55	0.55	0.55	0.55
MAX. TRACTION (KG)	200	200	200	200
BELT SPEED (CM/S)	20-80	20-80	20-80	20-80
VOLTAGE (VOLT)	230	230	230	230

All prices on request.

ACCESSORIES

- ◆ CARRIAGE
- ◆ HOPPER
- ◆ SUPPORT LEGS
- ◆ CE-EXTENSION CABLE FOR SERIES CONNECTION
- ◆ VARIOUS TYPES OF SUPPORT ELEMENTS

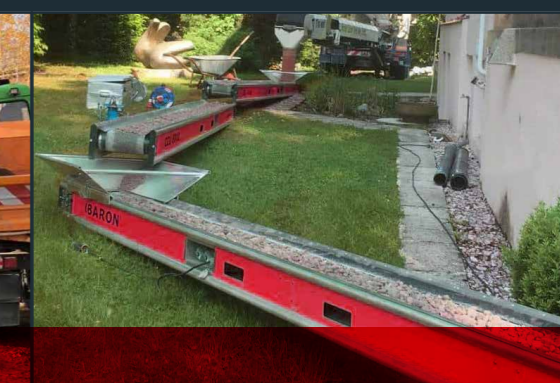
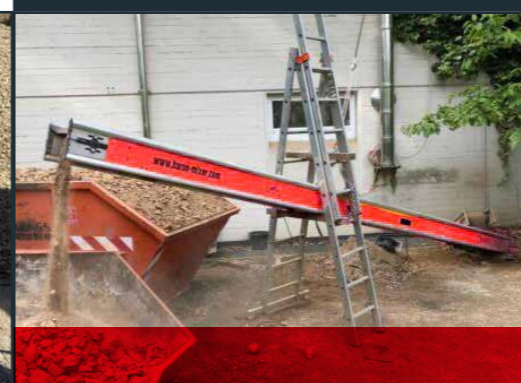



CONTACT

 XAVA Recycling e.U.
Tannbergstraße 10, 4132 Lembach i.M., AUSTRIA

 +43 (660) 43 44 420

 office@xava-recycling.at
www.xava-recycling.at



XAVA YOUTUBE CHANNEL