

SERIE MK

FRANTUMATORE MULTI KIT MULTI KIT PULVERIZER BROYEUR MULTI KIT DEMOLEDOR MULTI KIT MEHRZWECKGERÄT MULTI KIT GARRA DEMOLIDORA MULTIFUNÇÕES

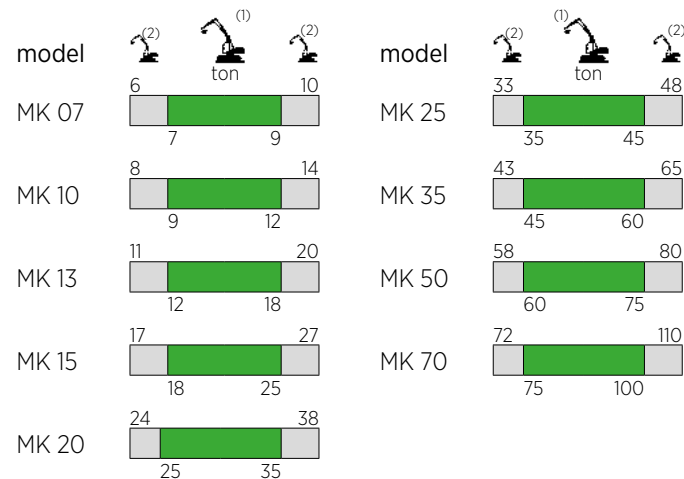

(1) Accoppiamento escavatore-attrezzatura ottimale
Optimum excavator-equipment combination
Couplage pelle-équipement optimal
Acoplamiento excavadora-implemento optimal
Optimale Bagger-Ausrüstung Kombination
Combinação máquina-implemento ideal

(2) Accoppiamento escavatore-attrezzatura possibile
Possible excavator-equipment combination
Couplage pelle-équipement possible
Acoplamiento excavadora-implemento possible
Mögliche Bagger-Ausrüstung Kombination
Combinação máquina-implemento possível

		MK 07 *	MK 10 *	MK 13 *	MK 15	MK 20	MK 25	MK 35	MK 50	MK 70
	kg.	410	570	795	1205	1490	1970	2150	3470	5020
H1**	mm.	810	1000	1055	1220	1330	1370	1375	1540	1720
	bar	280	310	310	310	310	310	310	340	340
	l/min.	80 / 150	150 / 250	180 / 250	180 / 250	200 / 300	250 / 350	300 / 400	400 / 500	450 / 600
	bar	140	140	140	140	140	140	140	140	140
	l/min.	10	10	10	10	10	10	10	30	30
		/	/	/	/	/	/	/	✓	✓

*Versione meccanica / **Mechanical version / *Version mécanique / *Versión mecánica / *Mechanischer Version

**H = H1 + H2

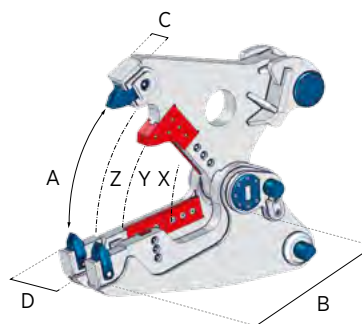

		Kit CB								
		MK 07	MK 10	MK 13	MK 15	MK 20	MK 25	MK 35	MK 50	MK 70
	kg.	*	450	585	720	1090	1305	1780	2900	3890
A	mm.	*	580	640	740	810	850	910	990	1160
B	mm.	*	560	700	720	800	815	875	1065	1180
C	mm.	*	100	100	110	130	130	130	175	185
D	mm.	*	290	310	320	350	410	410	560	610
	mm.	*	350	400	420	480	500	500	575	640
H2**	mm.	*	800	920	1000	1125	1155	1255	1490	1640
X	t.	*	220	270	420	510	700	740	900	1010
Y	t.	*	60	65	100	125	155	175	220	290
Z	t.	*	40	50	65	80	100	115	140	185
∅ max	mm.	*	30	35	40	45	50	55	70	85
	mm.	/	/	/	/	/	/	/	/	/
	mm.	/	/	/	/	/	/	/	/	/
	mm.	/	/	/	/	/	/	/	/	/

(*) Disponibile su richiesta / (*) Available on request / (*) Disponible sur demande / (*) Disponible a petición / (*) Verfügar auf Anfrage
(*) Disponivel para pedido

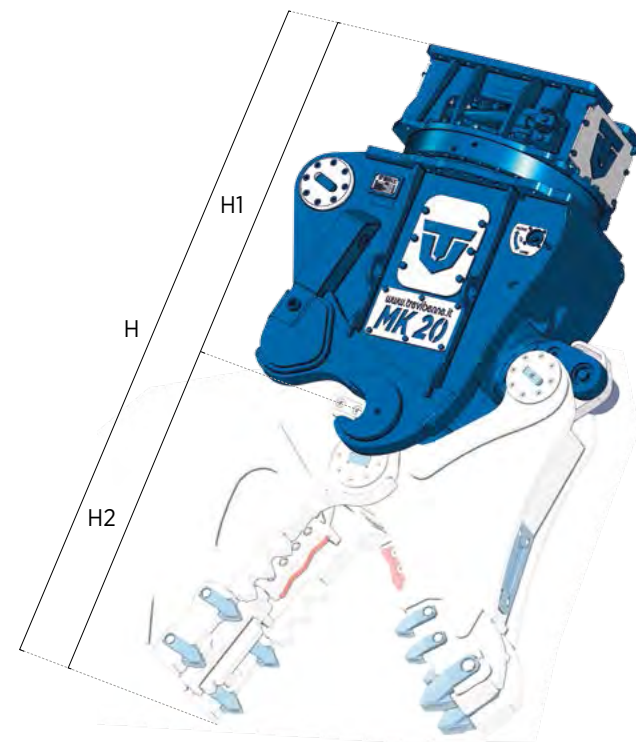

		Kit CH								
		MK 07	MK 10	MK 13	MK 15	MK 20	MK 25	MK 35	MK 50	MK 70
	kg.	*	*	610	740	1000	1300	1590	2720	*
A	mm.	*	*	445	500	635	550	720	880	*
B	mm.	*	*	580	615	750	785	960	1025	*
C	mm.	*	*	235	275	295	350	350	425	*
D	mm.	*	*	335	395	415	475	475	565	*
	mm.	*	*	530	530	660	600	750	875	*
H2**	mm.	*	*	900	910	1080	1100	1280	1480	*
X	t.	*	*	245	260	375	720	740	810	*
Y	t.	*	*	105	115	150	215	220	270	*
Z	t.	*	*	60	80	100	130	135	150	*
∅ max	mm.	*	*	40	45	50	55	60	65	*
	mm.	/	/	/	/	/	/	/	/	/
	mm.	/	/	/	/	/	/	/	/	/
	mm.	/	/	/	/	/	/	/	/	/

(*) Disponibile su richiesta / (*) Available on request / (*) Disponible sur demande / (*) Disponible a petición / (*) Verfügar auf Anfrage
(*) Disponivel para pedido

SERIE MK

FRANTUMATORE MULTI KIT MULTI KIT PULVERIZER BROYEUR MULTI KIT DEMOLEDOR MULTI KIT MEHRZWECKGERÄT MULTI KIT GARRA DEMOLIDORA MULTIFUNÇÕES

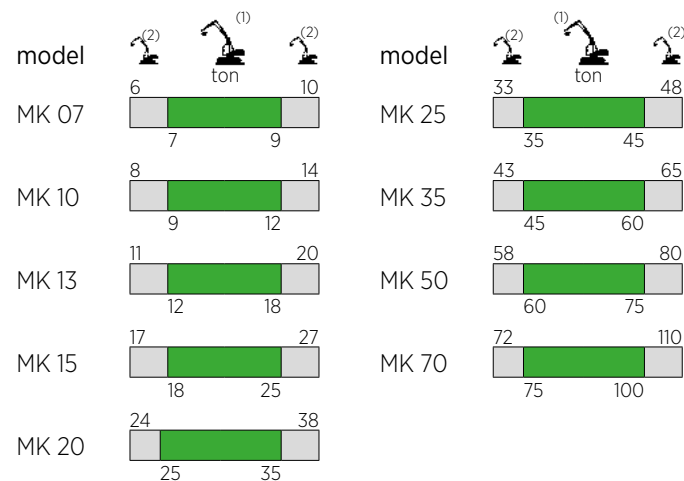

(1) Accoppiamento escavatore-attrezzatura ottimale
Optimum excavator-equipment combination
Couplage pelle-équipement optimal
Acomplamiento excavadora-implemento optimal
Optimale Bagger-Ausrüstung Kombination
Combinação máquina-implemento ideal

(2) Accoppiamento escavatore-attrezzatura possibile
Possible excavator-equipment combination
Couplage pelle-équipement possible
Acomplamiento excavadora-implemento posible
Mögliche Bagger-Ausrüstung Kombination
Combinação máquina-implemento possível

		MK 07 *	MK 10 *	MK 13 *	MK 15	MK 20	MK 25	MK 35	MK 50	MK 70
	kg.	410	570	795	1205	1490	1970	2150	3470	5020
H1**	mm.	810	1000	1055	1220	1330	1370	1375	1540	1720
	bar	280	310	310	310	310	310	310	340	340
	l/min.	80 / 150	150 / 250	180 / 250	180 / 250	200 / 300	250 / 350	300 / 400	400 / 500	450 / 600
	bar	140	140	140	140	140	140	140	140	140
	l/min.	10	10	10	10	10	10	10	30	30
		/	/	/	/	/	/	/	✓	✓

*Versione meccanica / **Mechanical version / *Version mécanique / *Versión mecánica / *Mechanischer Version
**H = H1 + H2



		Kit HC								
		MK 07	MK 10	MK 13	MK 15	MK 20	MK 25	MK 35	MK 50	MK 70
	kg.	250	435	575	680	1075	1235	1700	2750	*
A	mm.	525	600	740	835	920	945	1010	1150	*
B	mm.	490	610	710	740	765	815	875	1070	*
C	mm.	90	100	100	110	130	130	130	175	*
D	mm.	240	300	300	340	350	400	450	550	*
	mm.	125	150	200	175	240	250	250	290	*
H2**	mm.	690	810	925	1005	1125	1170	1275	1500	*
X	t.	100	135	165	220	290	350	385	465	*
Y	t.	45	60	75	90	130	150	180	220	*
Z	t.	30	40	50	65	85	105	115	140	*
∅ max	mm.	20	25	30	35	40	45	50	60	*
	mm.	/	/	/	/	/	/	/	/	/
	mm.	/	/	/	/	/	/	/	/	/
	mm.	/	/	/	/	/	/	/	/	/

(*) Disponibile su richiesta / (*) Available on request / (*) Disponible sur demande / (*) Disponible a petición / (*) Verfügar auf Anfrage
(*) Disponivel para pedido

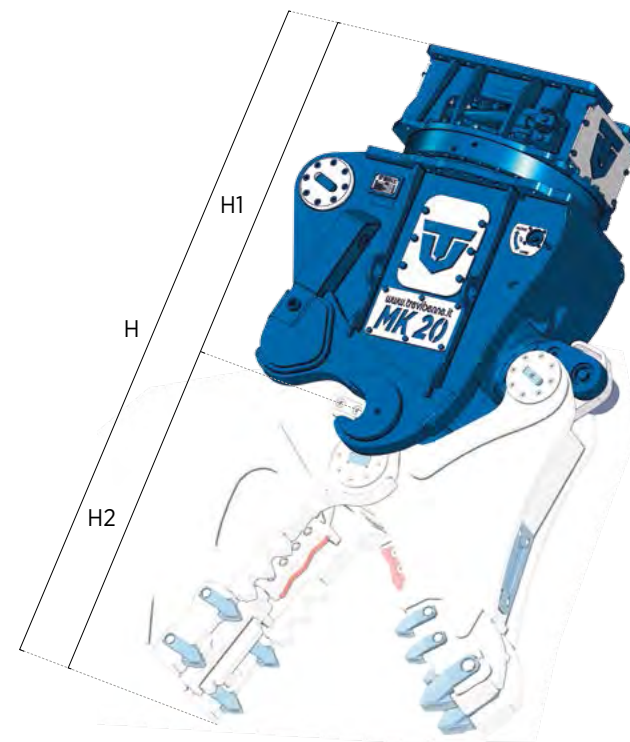
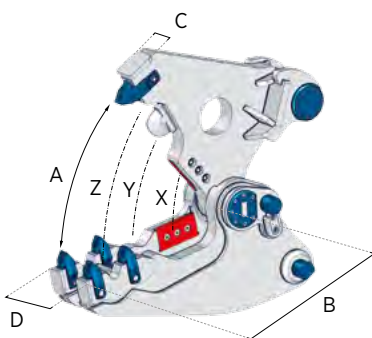

		Kit CL								
		MK 07	MK 10	MK 13	MK 15	MK 20	MK 25	MK 35	MK 50	MK 70
	kg.	*	*	*	560	1000	1400	1750	*	*
A	mm.	*	*	*	270	350	370	400	*	*
B	mm.	*	*	*	360	465	520	780	*	*
C	mm.	*	*	*	115	145	150	160	*	*
D	mm.	*	*	*	310	390	440	480	*	*
	mm.	*	*	*	320	400	430	480	*	*
H2**	mm.	*	*	*	505	630	695	750	*	*
X	t.	*	*	*	220	270	320	350	*	*
Y	t.	*	*	*	150	200	225	230	*	*
Z	t.	/	/	/	110	140	160	170	*	*
∅ max	mm.	/	/	/	/	/	/	/	/	/
	mm.	/	/	/	/	/	/	/	/	/
	mm.	/	/	/	/	/	/	/	/	/
	mm.	*	*	*	10	12	14	16	*	*

(*) Disponibile su richiesta / (*) Available on request / (*) Disponible sur demande / (*) Disponible a petición / (*) Verfügar auf Anfrage
(*) Disponivel para pedido