

PRODUCT NEWS AND DEVELOPMENTS 2016



By Chris Goebel June 2016

Seite 1

NEW PRODUCTS AND DEVELOPMENTS

ER50 >> With stronger picks

ER50 cutting drums with pick box PH50N
(i.e. 2 x 28 picks with 15 mm shank diameter)



Previous ER50 cutting drums
with pick box PH50
(i.e. 2 x 30 picks with 11,4 mm shank)

New ER50 cutting drums
with pick box PH50N
(i.e. 2 x 28 picks with 15 mm shank)



NEW PRODUCTS AND DEVELOPMENTS

Improvement on ER650 cutting heads

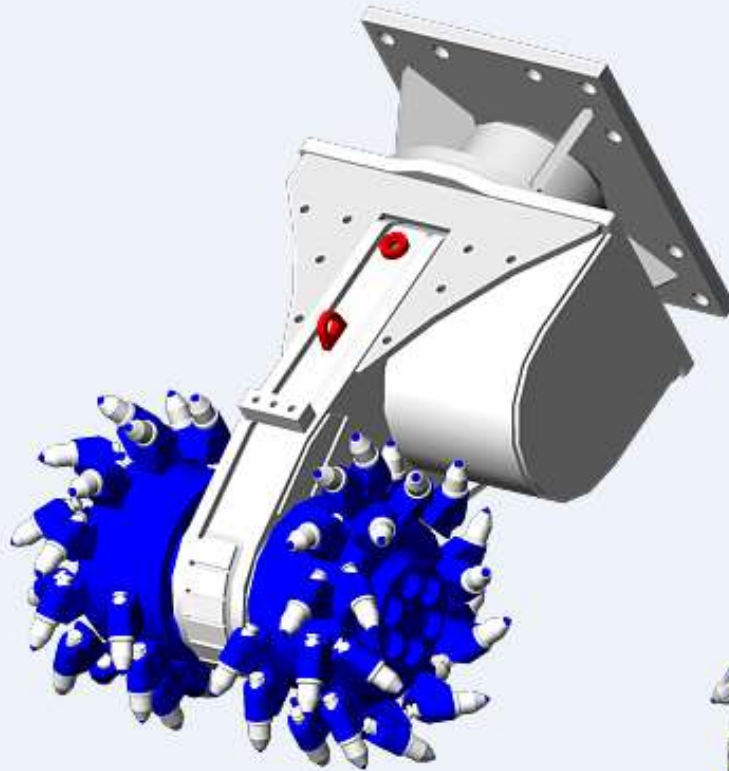

Previous model till 12/2015

2 x 24 picks

ER 17/64/60/25 Q

(25 mm shank diameter)

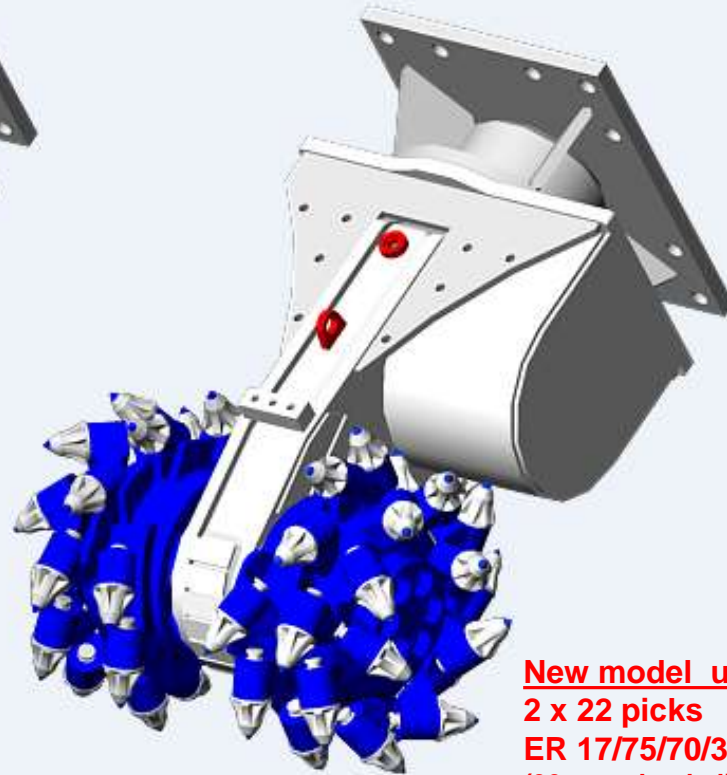

New model up from 01/2016

2 x 22 picks

ER 17/75/70/30 Q

(30 mm shank diameter)

NEW PRODUCTS AND DEVELOPMENTS

Improvement on ER650 cutting heads



Up from 01/2016
2 x 22 picks
ER 17/75/70/30 Q
(30 mm shank diameter)



NEW PRODUCTS AND DEVELOPMENTS

ER1700 >> New Model based on ER1500-HD

Series ER 1700

erkat ROTARY DRUM CUTTERS

With transverse cutting heads (standard)

**Recommended excavator
weight: 30 – 50 tons**

Weight: 2,200 kg

Rated power: 120 kW



**Reinforced gear case
(thicker steel plates)**

**Stronger hydraulic motor
with more output torque**

**Larger drive shaft flange
fixing bolts**

**Thicker wear protection
plates at the front
gear case**

NEW PRODUCTS AND DEVELOPMENTS

ER1700 >> New Model based on ER1500-HD

		ER 1700
Length of drum cutter (A)	mm	1420
Width of drum cutter (B)	mm	1.040
Diameter of cutting head ©	mm	720
Weight	kg	2.200
Number of picks	pcs	56

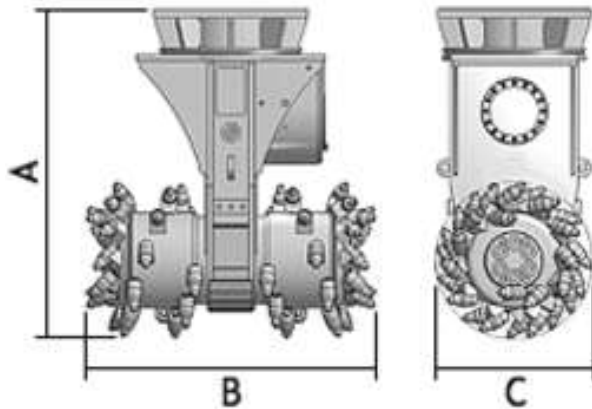

		ER 1700-1	ER 1700-3
Rated drive power	kW	120	120
Recom. excavator weight	t	30 - 45	30 - 45
Recom. oil flow rate at 50 bar	l/min	290	360
max. oil flow rate	l/min	360	400
max operating pressure	bar	380	380
Cutting drum speed	1/min	72	72
Cutter drum torque at 380 bar	Nm	25.300	30.300
Cutting force at 380 bar	N	70.300	84.200
Cutting head diameter	mm	720	720
Cutting head width	mm	1.040	1.040
Number of cutting picks	qty	56	56
Operating weight	kg	2.200	2.200
Standard pick type	type	ER 19/75/70/30 Q	

NEW PRODUCTS AND DEVELOPMENTS

ER50-X Transverse Cutter with Small Cutting Width

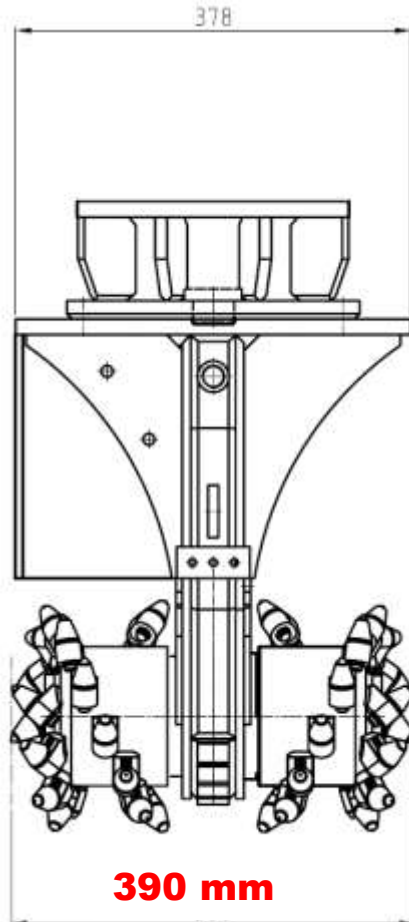

Picks with 12 mm shank diameter

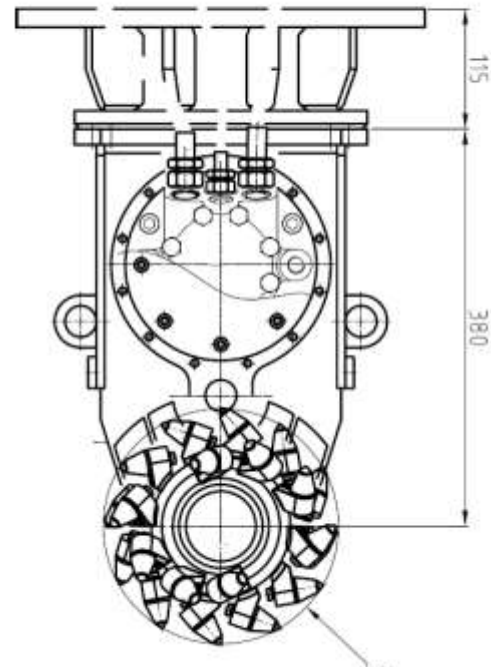

Ø 225 mm

Standard ER50

- Cutting Width = 480 mm
- Cutting drum dia = 225 mm
- Pick with 12 mm shank diameter

Seite 7

NEW PRODUCTS AND DEVELOPMENTS

ER100-X Transverse Cutter with Small Cutting Width

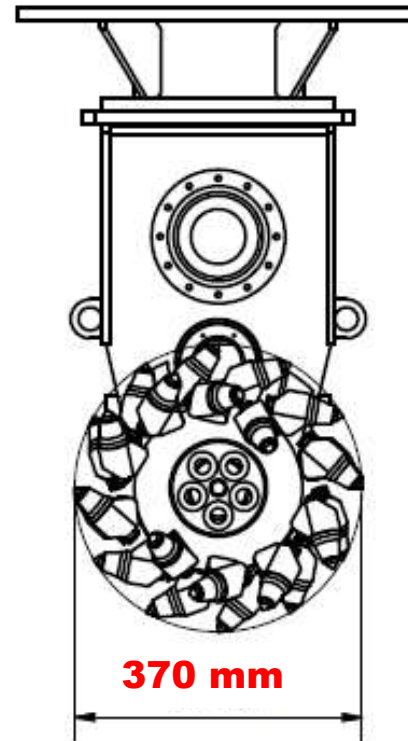
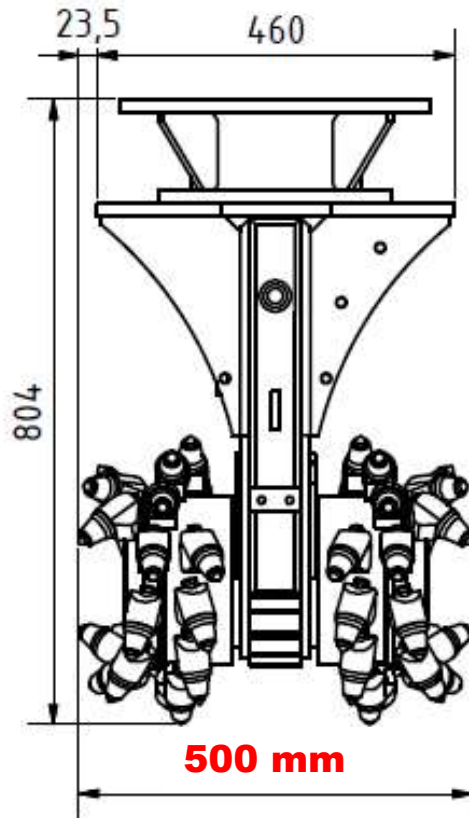

Picks with 20 mm shank diameter



Standard ER100

- Cutting Width = 610 mm
- Cutting drum dia = 370 mm
- Pick with 20 mm shank diameter

Seite 8

NEW PRODUCTS AND DEVELOPMENTS

ER250-X Transverse Cutter with Small Cutting Width

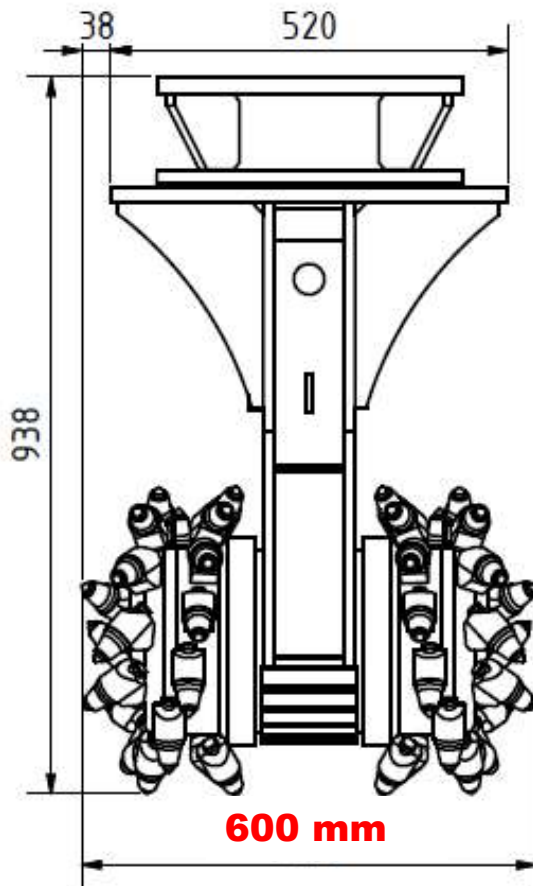

Picks with 20 mm shank diameter

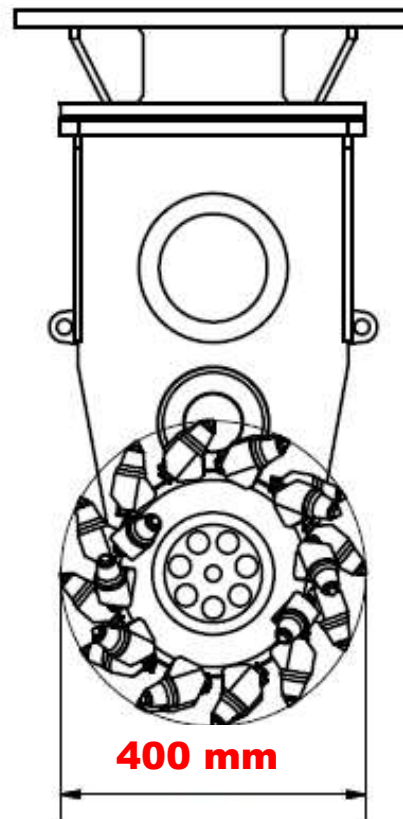

Standard ER250

- Cutting Width = 680 mm
- Cutting drum dia = 450 mm
- Pick with 22 mm shank diameter

NEW PRODUCTS AND DEVELOPMENTS

Improvement of ER2000 Transverse Drum Cutter

**ER2000 with more robust gear housing
now suitable for excavators 35 – 55 to**

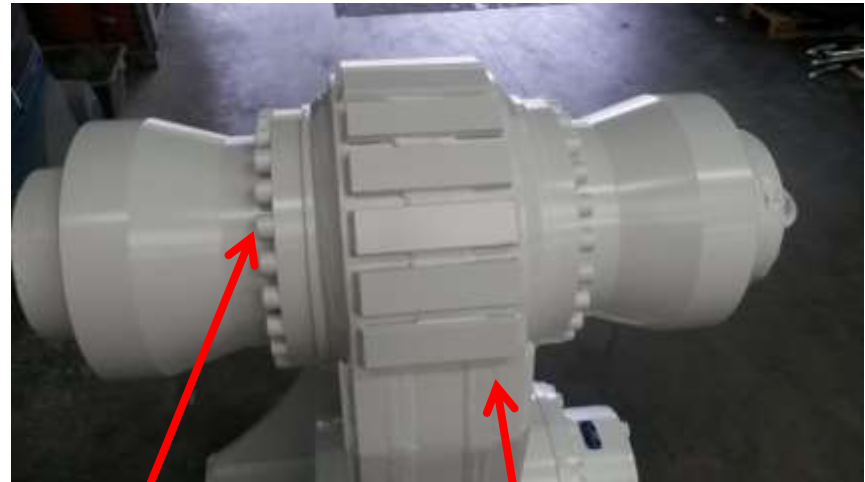
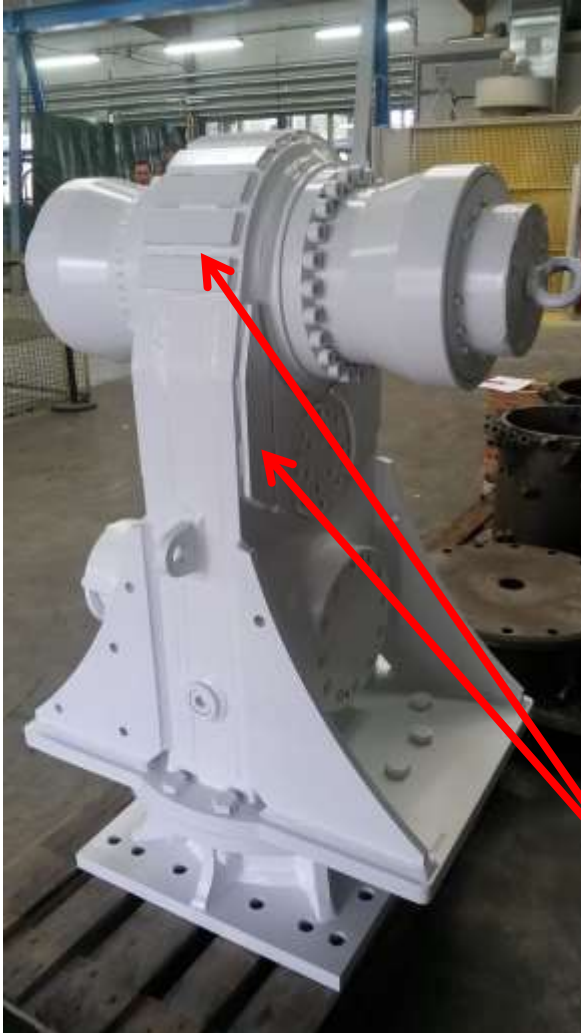

**Increased thickness of
wear protection plates**

**Increased size / diameter of
flange bolts**

**Increased thickness of gear box
side plates for more robustness**

NEW PRODUCTS AND DEVELOPMENTS

ER2000-XQ Transverse Cutter with Small Cutting Width equipped with new Multi Console

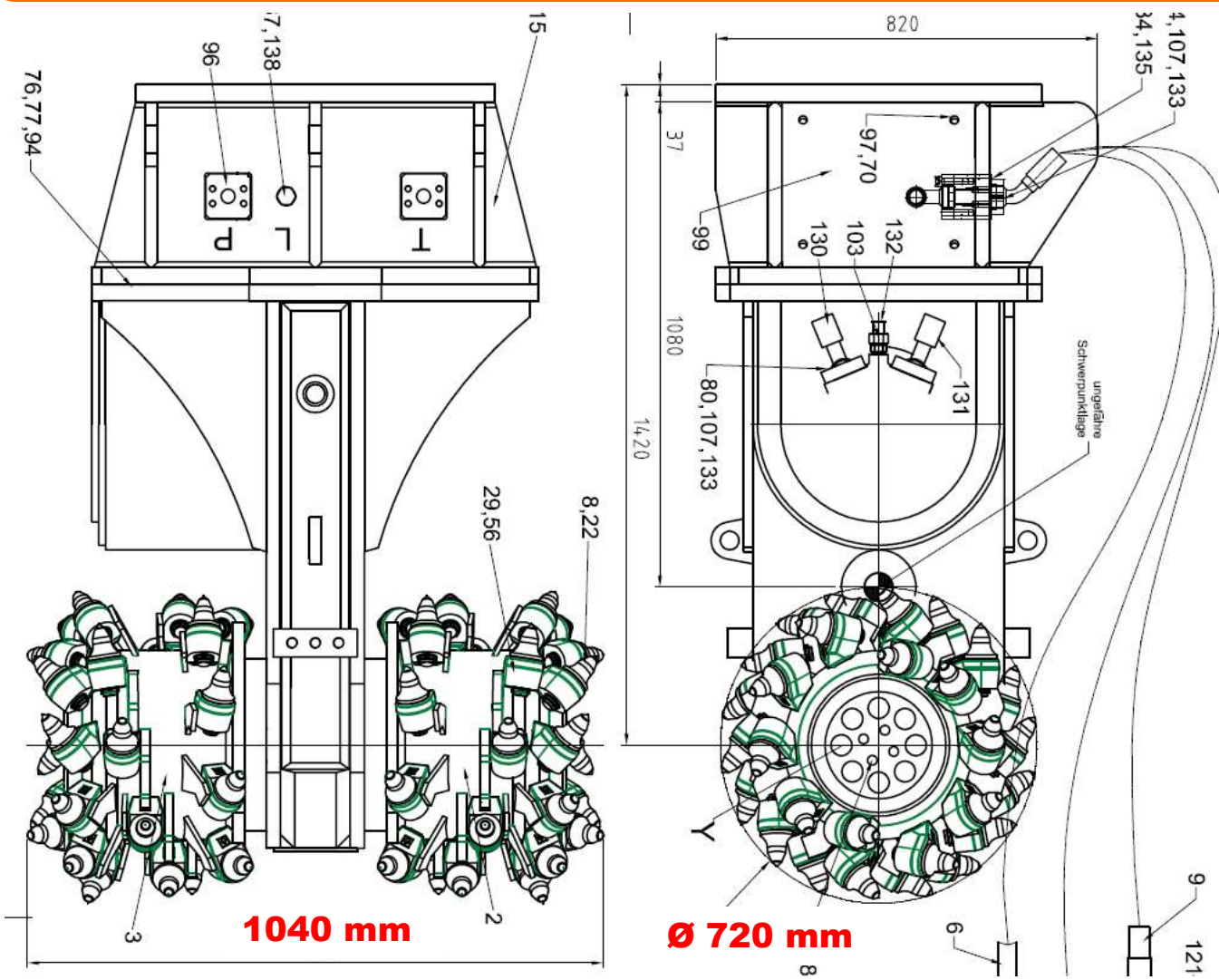

Special top bracket with hydraulic ports towards the rear side



NEW PRODUCTS AND DEVELOPMENTS

NEW MULTI CONSOLE for ER1500 + ER1700

Universal Multi Console offering the installation of following options:

- **Hydraulic hoses on the rear side of the cutter, so directly in line with the excavator boom**
- **Hydr. filter for pressure line, equipped with 50 µm or 10 µm filter insert**
- **Water spray system with up to 8 nozzles**
- **Drain oil line connection into return line, i.e. only two hoses (only in special cases, generally not recommended)**
- **Hydraulic pressure cut-off valve for the pressure line (i.e. pressure relief valve for restricting the max. working pressure for the motor)**
- **Hydraulic pressure cut-off valve for the drain line (i.e. pressure relief into the environment – not allowed in many states)**
- **Operating hour counter**

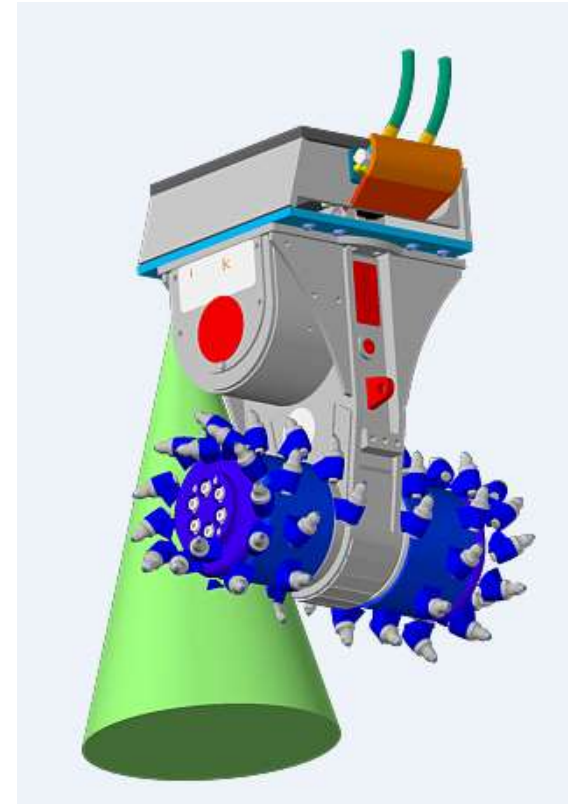

NEW PRODUCTS AND DEVELOPMENTS

MULTI FUNCTIONAL CONSOLE

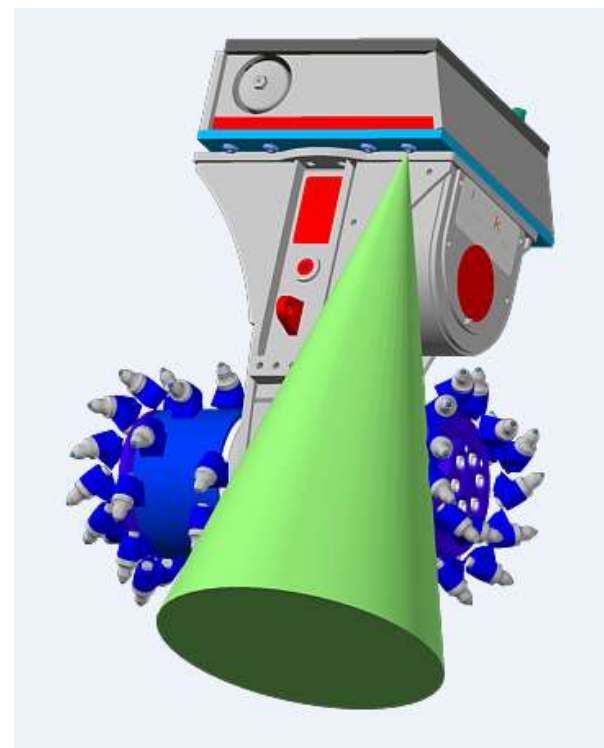
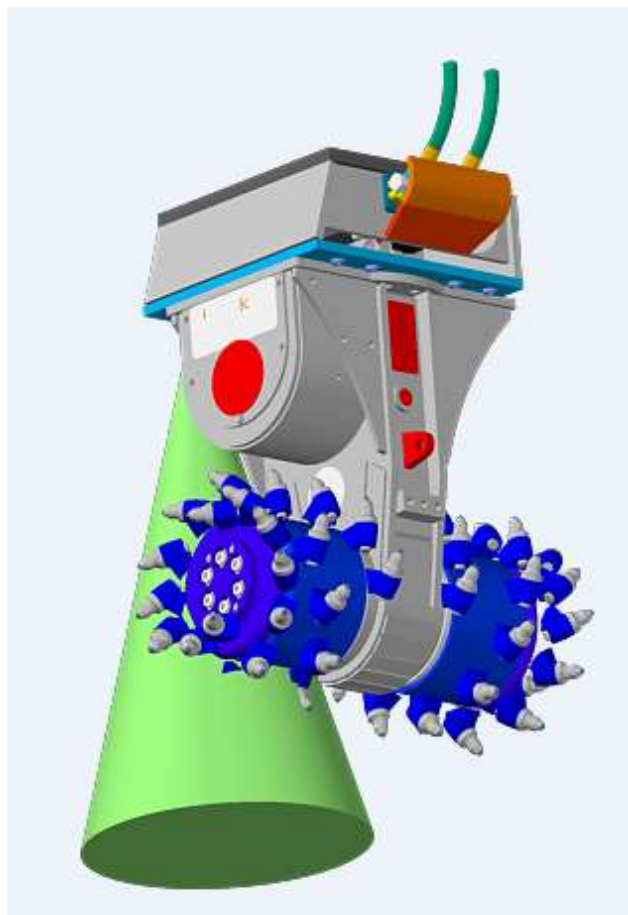

NEW PRODUCTS AND DEVELOPMENTS

NEW MULTI CONSOLE for ER1500 + ER1700



NEW PRODUCTS AND DEVELOPMENTS

ERC3000 with new ERU7



NEW PRODUCTS AND DEVELOPMENTS

ERC3000 with new ERU7



NEW PRODUCTS AND DEVELOPMENTS

ER1500 with DragonTooth Picks



ER1500-XL drums with 28 pick boxes per drum



ER1500-XL with DragonTooth picks
(pick box also allows standard step-shank pick 38/30 mm)

NEW PRODUCTS AND DEVELOPMENTS

ER2000 with Production Drums for Soft Rock

Standard Cutting Drums
(straight standard drum body design)

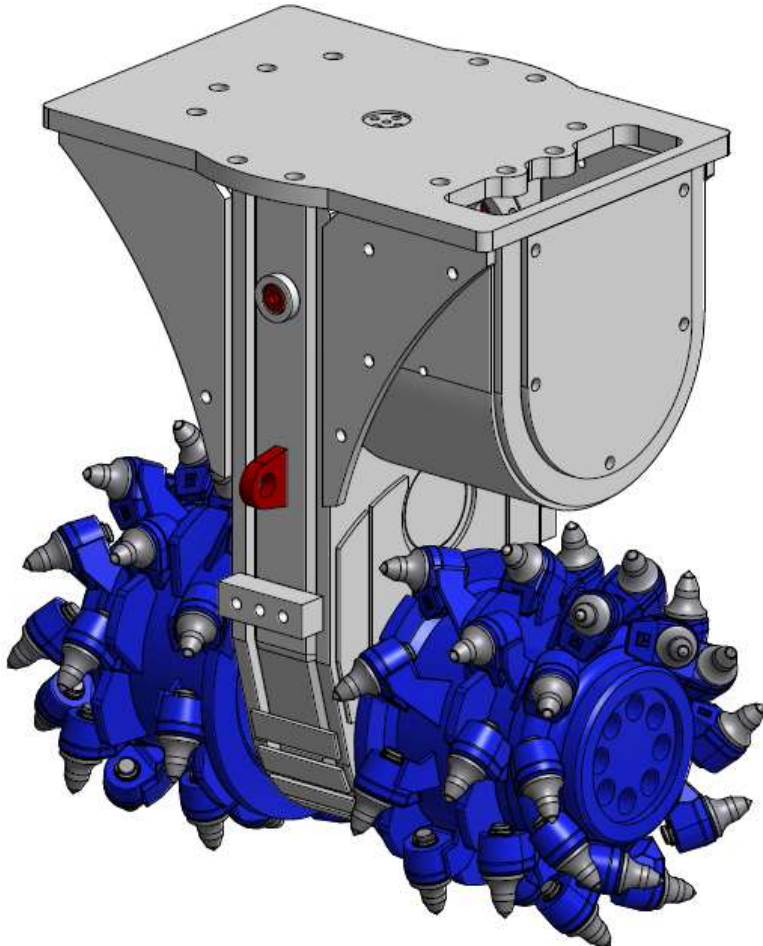

Production Drums for Soft Rock
(ball shape drum body design, less picks)

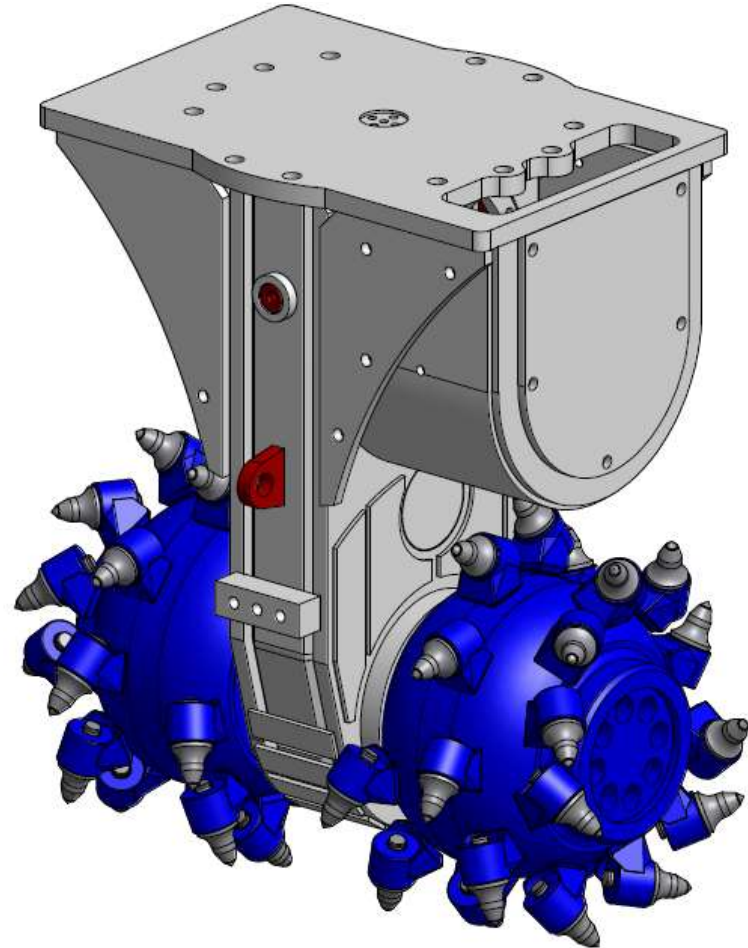

NEW PRODUCTS AND DEVELOPMENTS

New EBA2300 i.e. improvement of EBA2000 Drive Unit

New EBA 2300

Previous EBA 2000

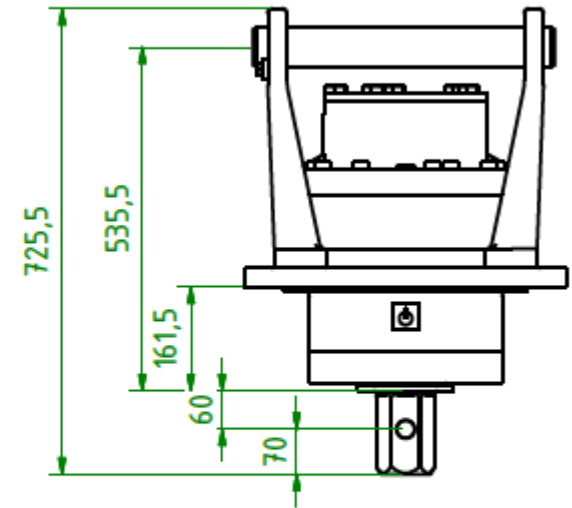
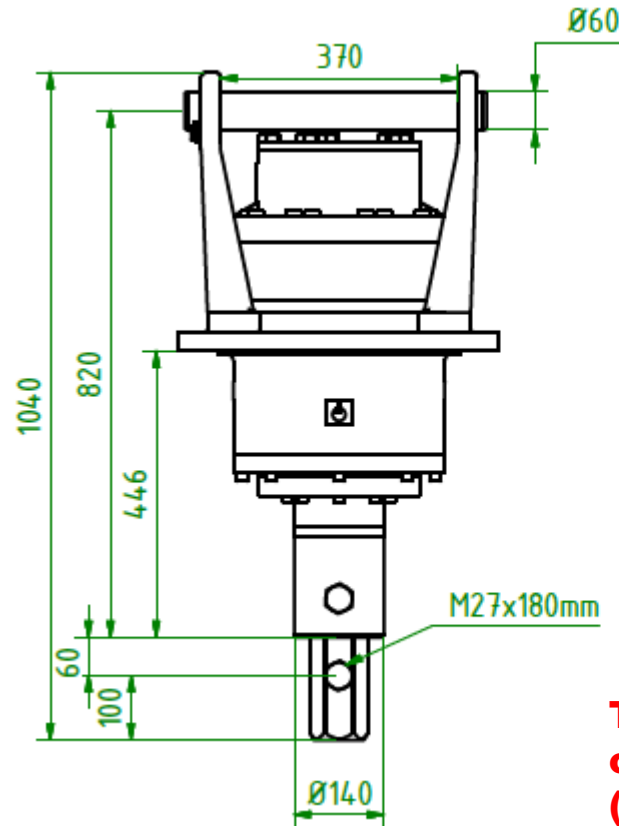
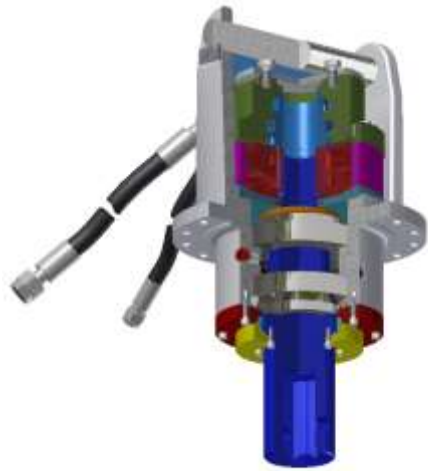

**Technical specs are identical,
only weight of EBA2300 is higher
(385 kg instead of 280 kg)**

NEW PRODUCTS AND DEVELOPMENTS

ERW1200 Wheel Cutter



ERW Series		ERW 1000	ERW 1200
Cutting width	mm	150 - 400	200 - 400
Standard cutting depth	mm	1000	1200
Drive unit torque at 350 bar	Nm	47.000	56.000
Max. oil flow at 50 bar	l/min	600	600
Recommended oil flow according to wheel diameter	l/min	300 - 550	400 - 550
Max. operating oil pressure	bar	350	350
Max. cutting force at 350 bar	kN	37,4	37,2
Max. diameter of rebar in concrete	mm	20	20
Weigth with max size wheel	kg	5500	7500
Rated power	kW	220	220
Recommended excavator weight	t	35 - 50	40 - 55
standard pick	type	ER17/75/70/30Q	ER19/75/70/30Q

NEW PRODUCTS AND DEVELOPMENTS

ERW1200 Wheel Cutter

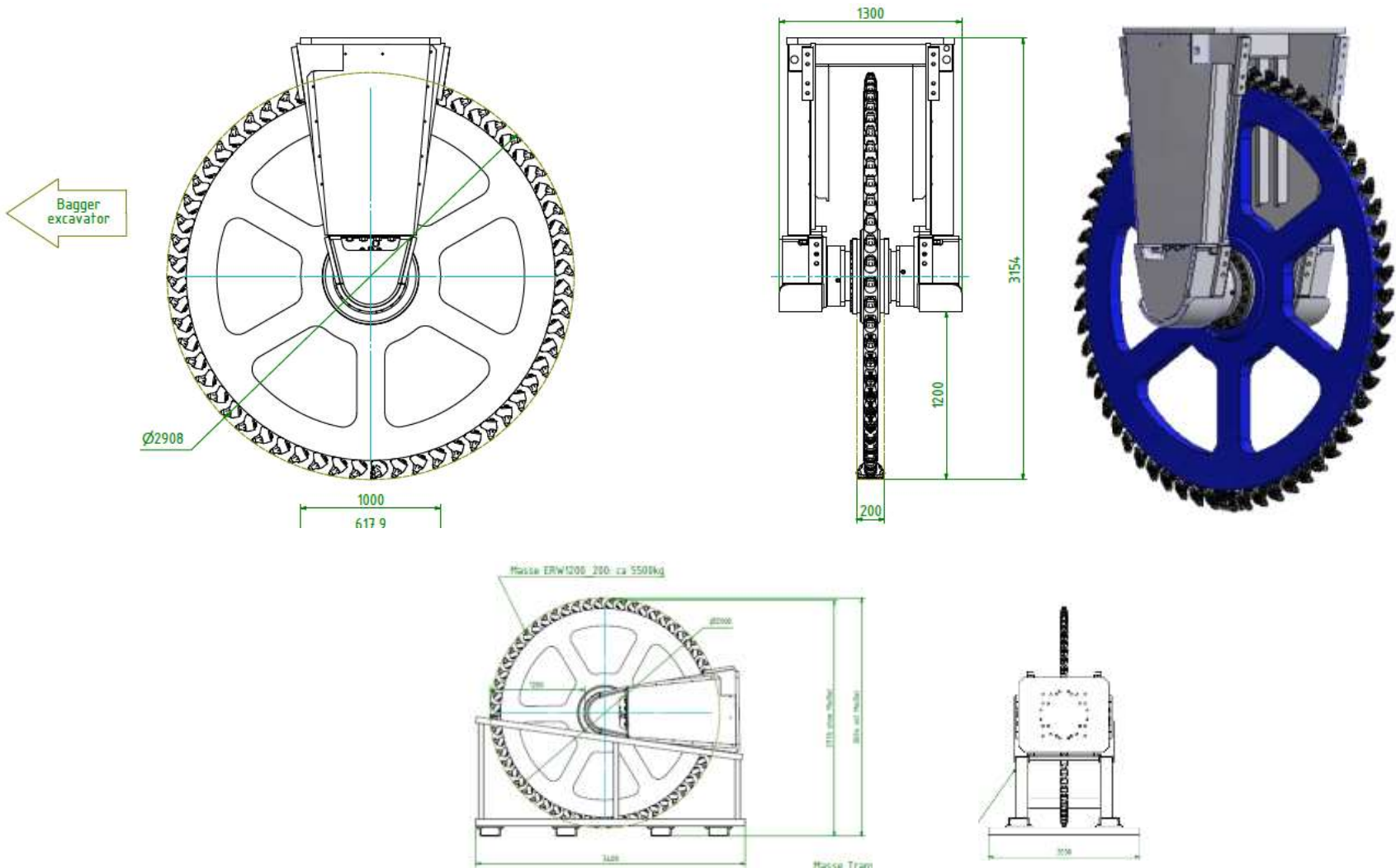

NEW PRODUCTS AND DEVELOPMENTS

Improvement for ERW series >> New Dipping Device

Dipping Device for Grade Cutting with ERW wheel cutter

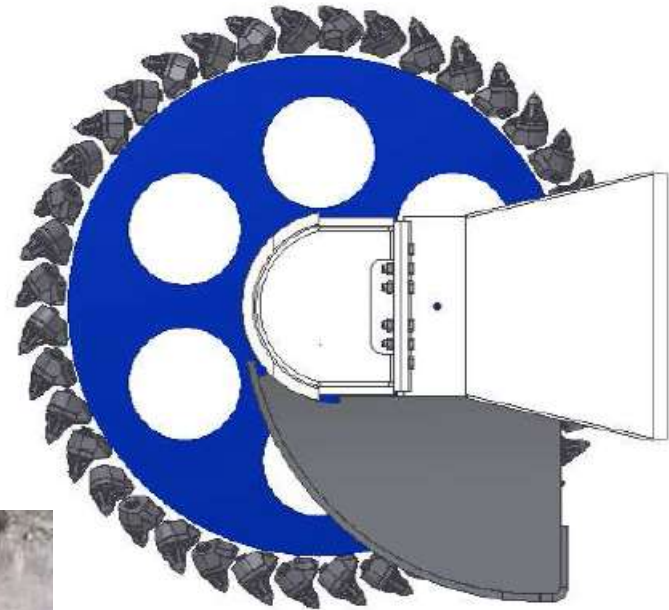
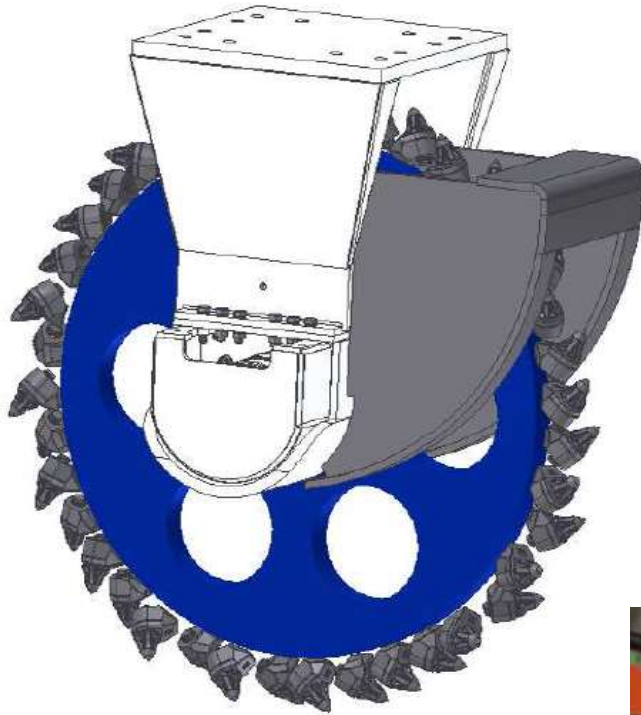

NEW PRODUCTS AND DEVELOPMENTS

Improvement for ERW series >> New Dipping Device

ERW Dipping device with material discharge for better trench cleaning



NEW PRODUCTS AND DEVELOPMENTS

Improvement for ERW600

Supporting Device for Grade Cutting with ERW wheel cutter



NEW PRODUCTS AND DEVELOPMENTS

ES60 with customised small slot cutter wheel



Slot cutter mounted on Kolbeco SK210
ES60-HD with customised cutter wheels

- Slot 200 x 80 mm >> 6 - 7 m/min
- Slot 100 x 80 mm >> 11 - 13 m/min



NEW PRODUCTS AND DEVELOPMENTS

ES60 with small slut cutter wheel



NEW PRODUCTS AND DEVELOPMENTS

EX/ES Mounting Bracket for Compact-Loader

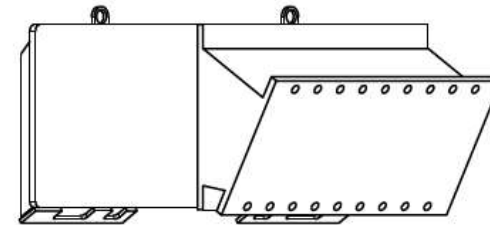
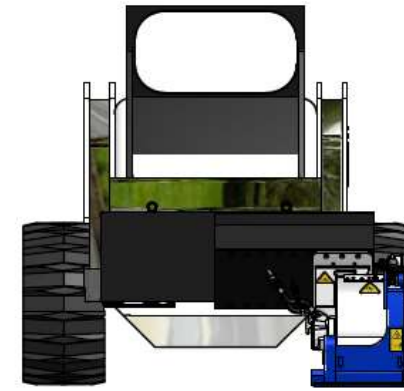
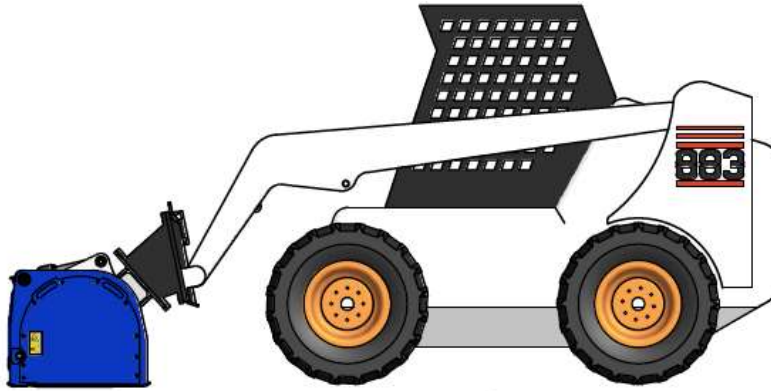

**EX planer simple side
adjustment via drill pattern
in the mounting bracket**

NEW PRODUCTS AND DEVELOPMENTS

EX/ES Mounting Bracket for Compact-Loader



NEW PRODUCTS AND DEVELOPMENTS

ES20 with brush drum for wall cleaning

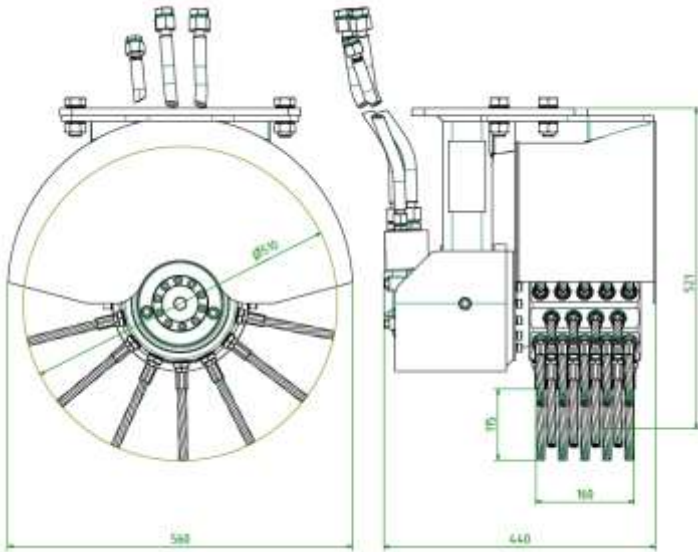

EX20 PLANER FOR MINI EXCAVATOR 1-3 to (here mounted on a Brokk 160)



EX20 On Brokk 160



NEW PRODUCTS AND DEVELOPMENTS

EX 20 Planer with different drums

Choice of cutting drums for different applications

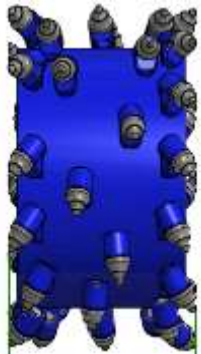
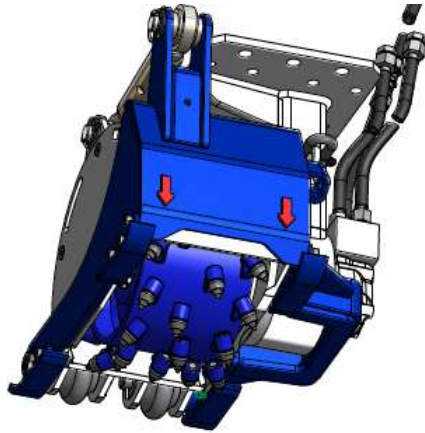

Standard Asphalt Drum

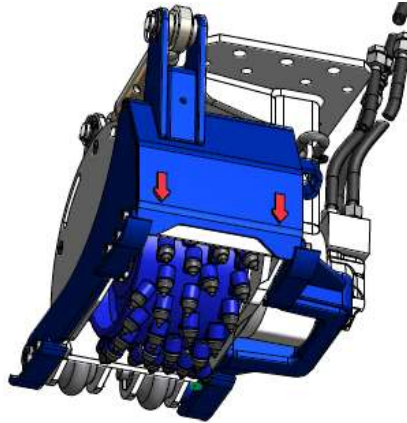

Fine Scaling Drum

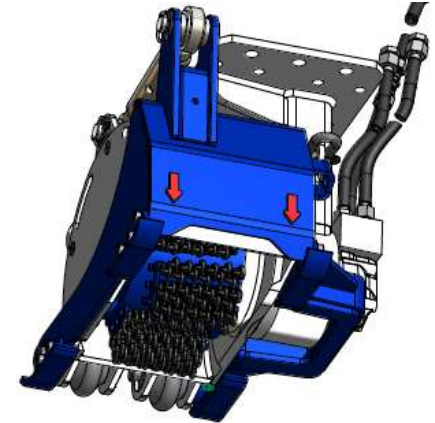

Chain Cleaning Drum

NEW PRODUCTS AND DEVELOPMENTS

EX Planer with Vacuum Dust Extraction



EX30 + 45 Planer With Connector Port for Vacuum Dust Extraction

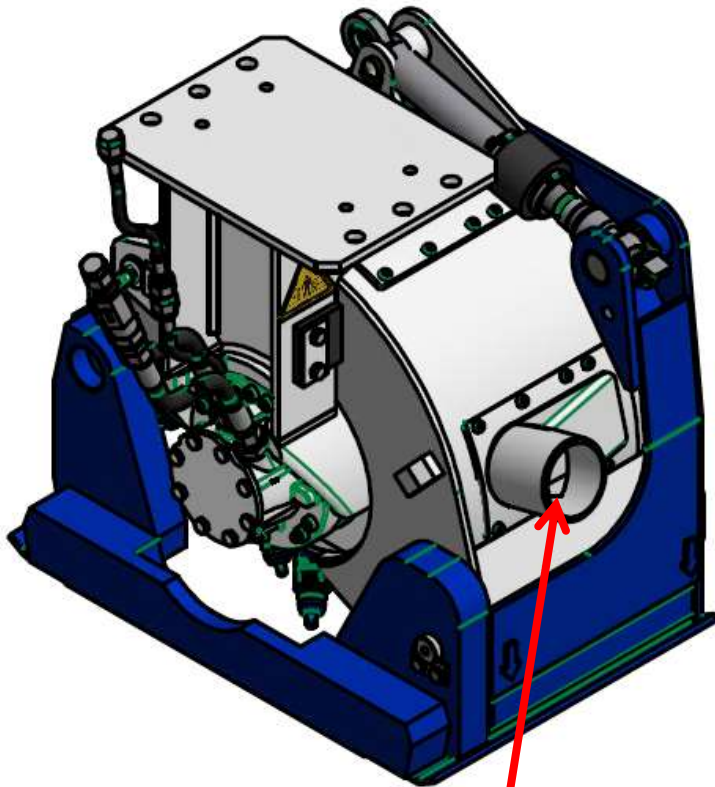

**Conecting port for dust vacuum extractor
(duct \varnothing 80 or 100 mm)**

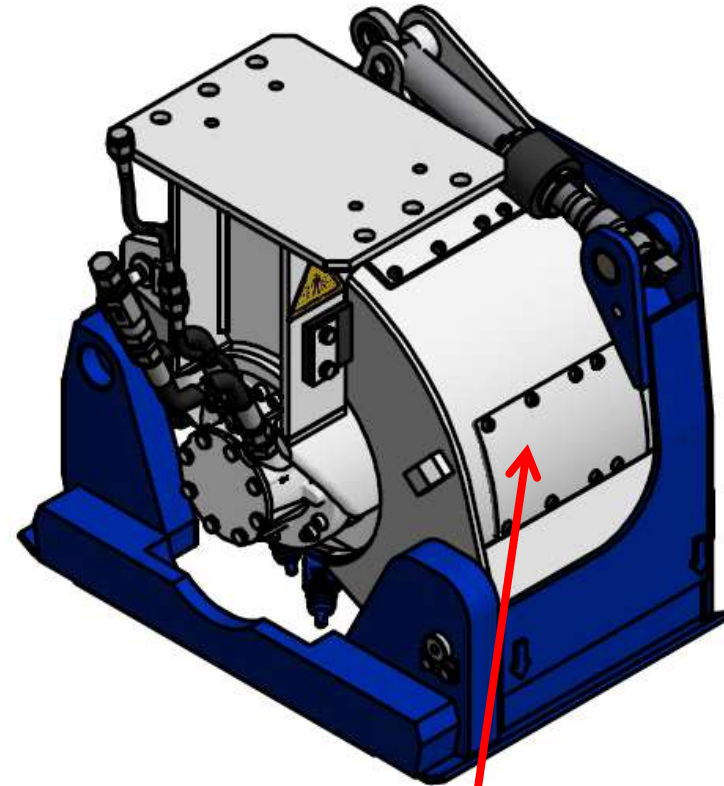

**Dust port closed by cover plate
(for normal use)**

NEW PRODUCTS AND DEVELOPMENTS

EX Planer with Vacuum Dust Extraction

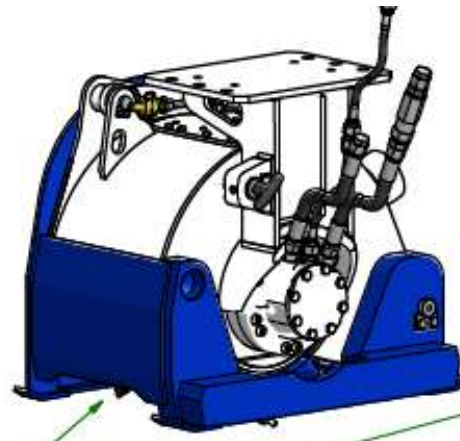

**Open cover hood
for air inlet**

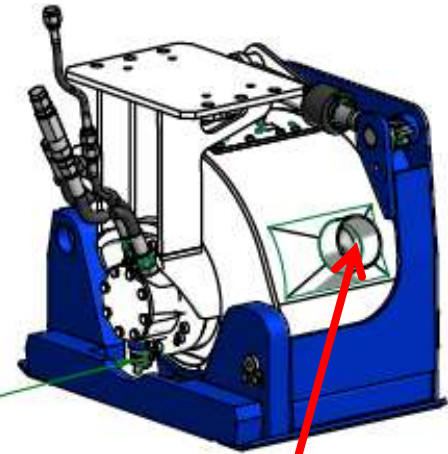

**Port for dust
collector duct**

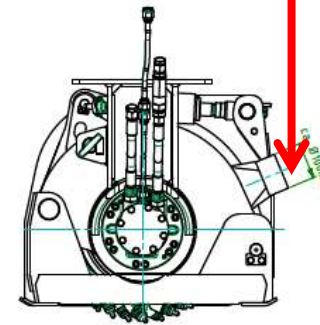

Example for Vacuum Dust Extractor



Motor power (kW)	11
Capacity (m ³ /h)	1100
Vacuum (bar)	0,28
Weight (kg)	365

www.dimu.de/dimu-sauger-t-11000.html



Motor power (kW)	5,75
Capacity (m ³ /h)	700
Vacuum (bar)	0,42
Weight (kg)	290

<http://www.husqvarna.com/de/construction/products/surface-preparation-products/dc-6000>

EX20 Planer with Protective Housing and Vacuum Dust Extraction System

EX20 with
dust extraction



EX20 Planer with Protective Housing and Vacuum Dust Extraction System

EX20 with chain cleaning drum



Painted steel surface



Concrete surface

NEW PRODUCTS AND DEVELOPMENTS

ERW with mechanical adjustable turntable

ERW with intermediate bracket for twisting, enabling off-set cutting beside the crawler track line

Intermediate bracket

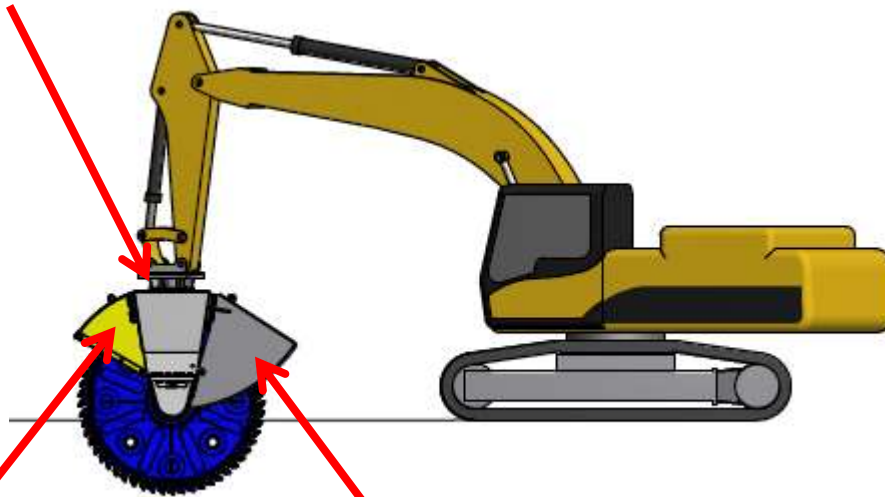

Protection cover

Dipping device

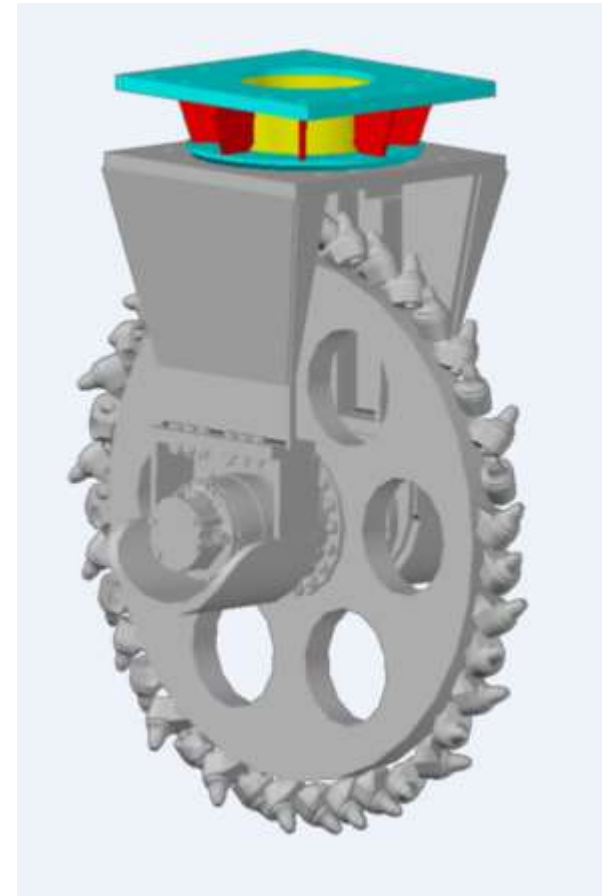

NEW PRODUCTS AND DEVELOPMENTS

ERW with mechanical adjustable turntable

New projects

ERW600 resp. ERW1000 with intermediate bracket for twisting, enabling off-set cutting beside the crawler track line

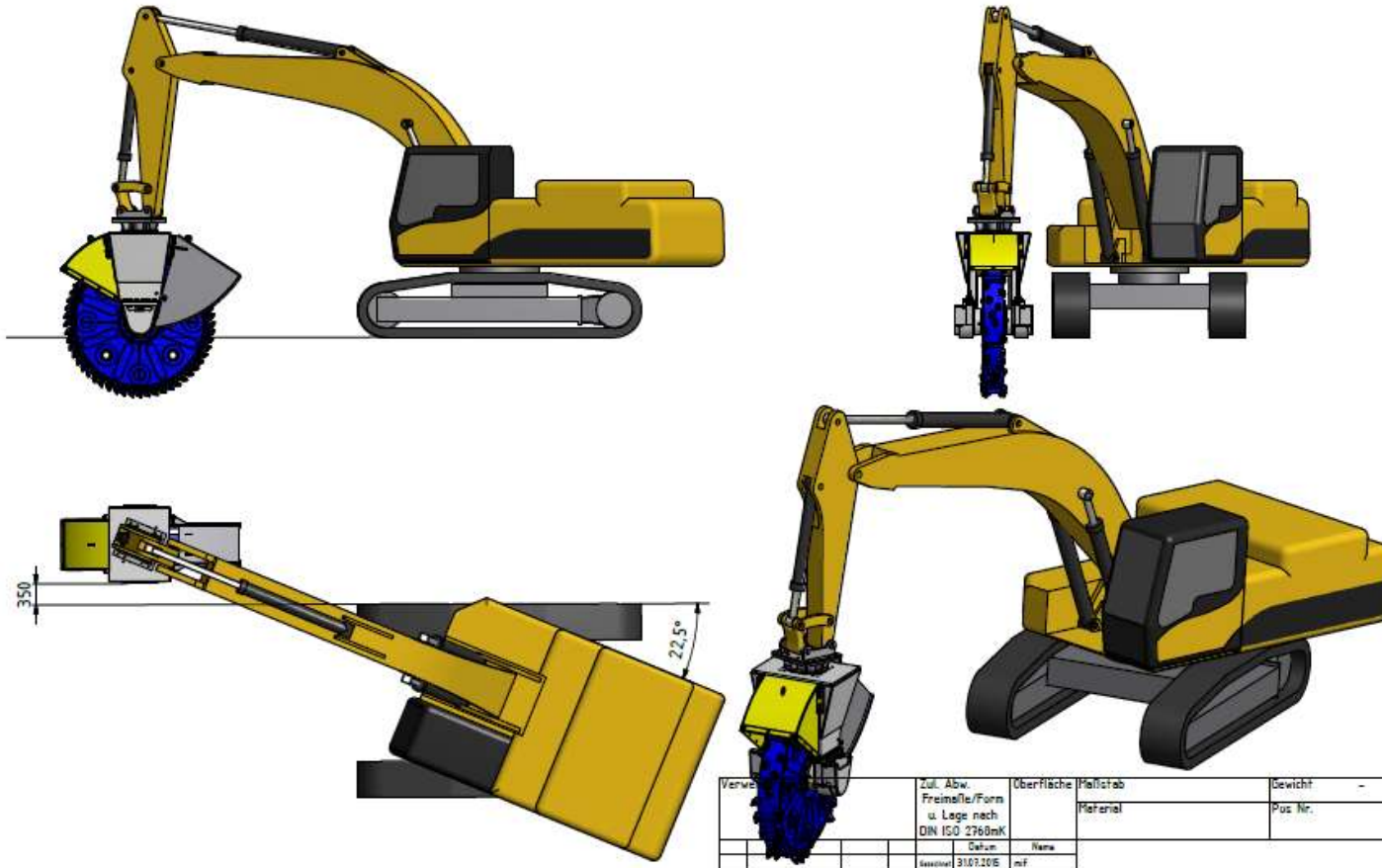

NEW PRODUCTS AND DEVELOPMENTS

ERW with adjustable turntable and protection cover

ERW600 with intermediate bracket for twisting, and protection covers



NEW PRODUCTS AND DEVELOPMENTS

ERW 600 with Turntable + Dipping Device + Protection Cover



NEW PRODUCTS AND DEVELOPMENTS

ERW 600 with Turntable + Dipping Device + Protection Cover

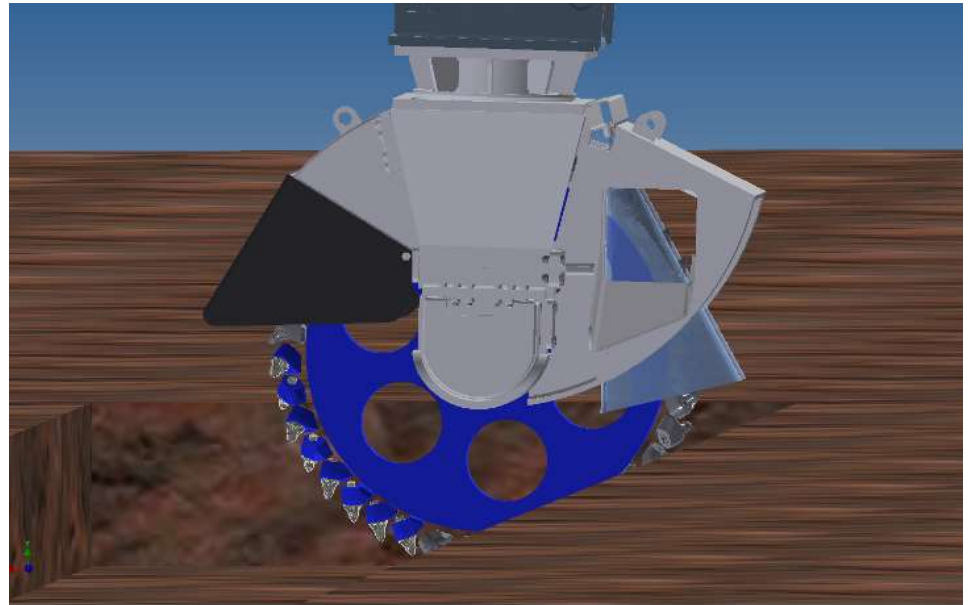
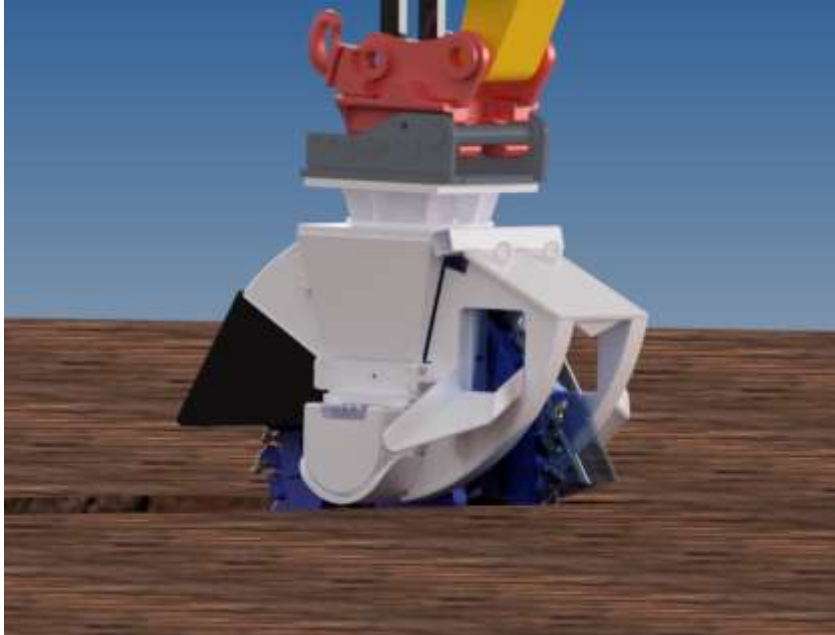

NEW PRODUCTS AND DEVELOPMENTS

ERW basic drive with new hose installation and protection

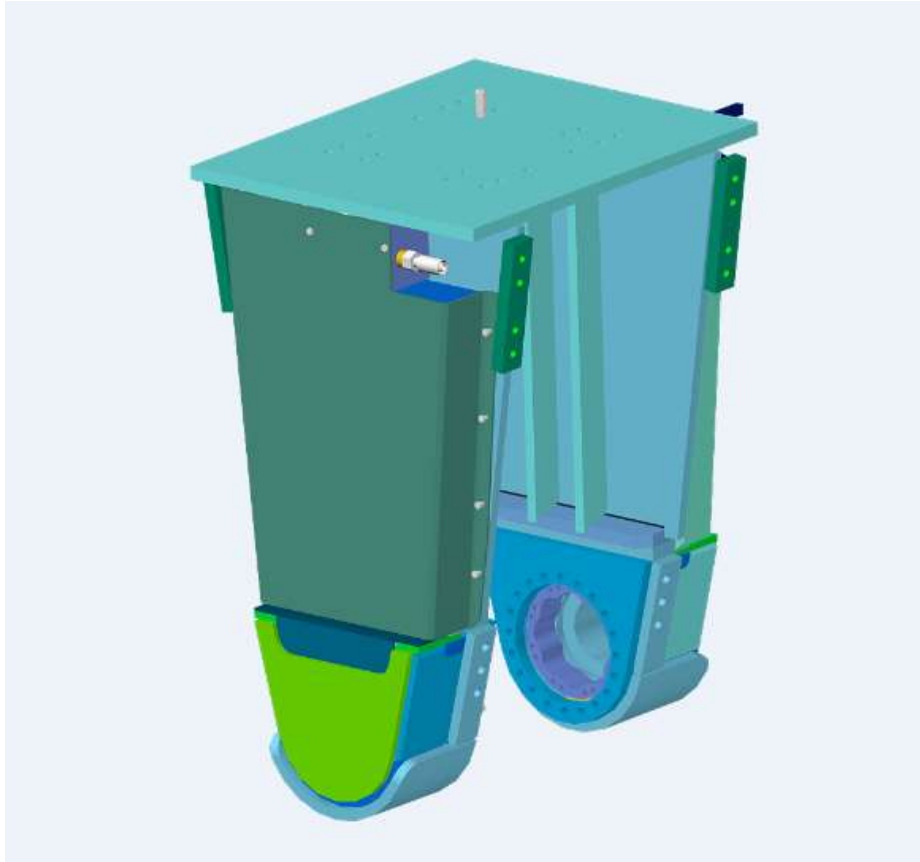

NEW PRODUCTS AND DEVELOPMENTS

New EK 600 CHAIN CUTTER

EK 600

- Suitable for excavators 18 - 28 to
- Cutting head width: 600 mm
- Drive power: 100 KW
- Recom. oil flow: 210 l/min
- Max. oil flow: 250 l/min
- Operating weight: approx. 2400 kg

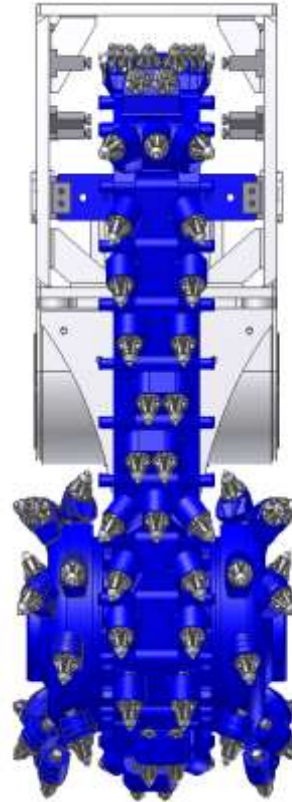
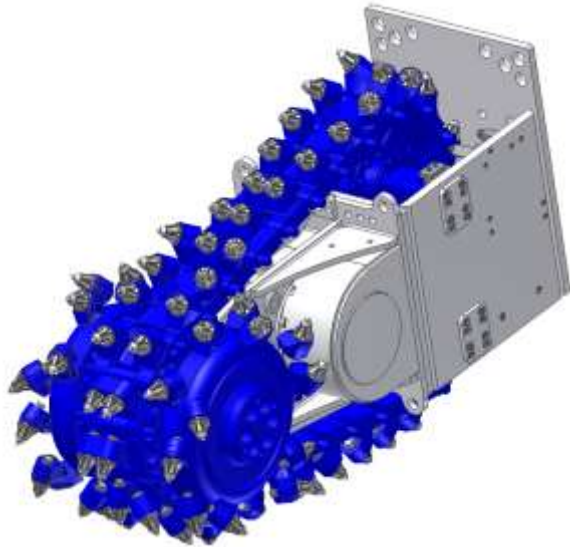

NEW PRODUCTS AND DEVELOPMENTS

EK 600 CHAIN CUTTER



NEW PRODUCTS AND DEVELOPMENTS

New Trenching Slot Cutter EST600

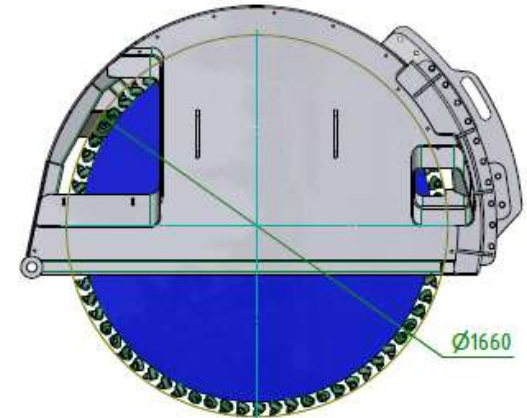
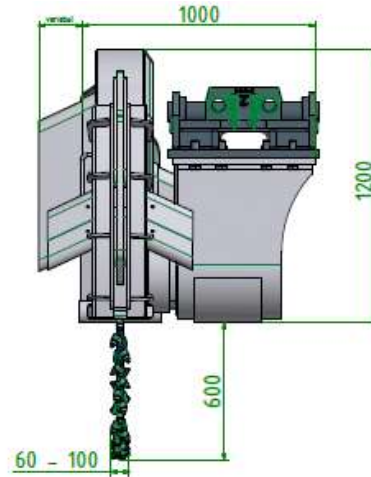
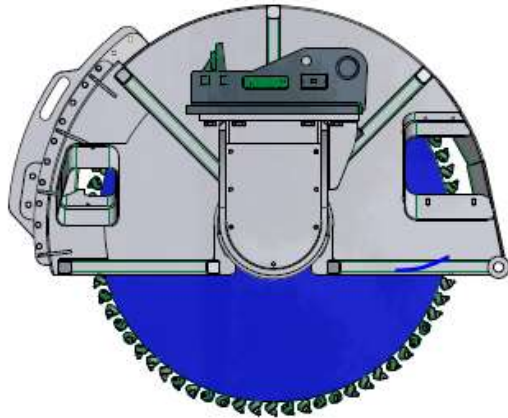

B-B

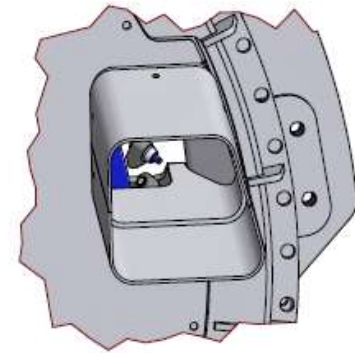
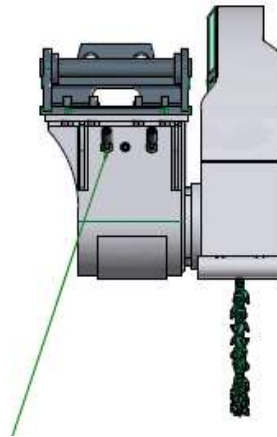
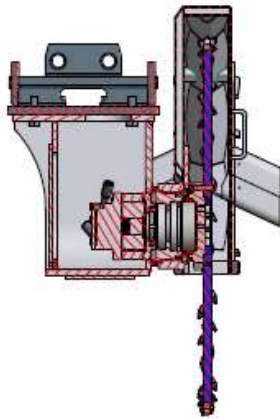

NEW PRODUCTS AND DEVELOPMENTS

New Trenching Slot Cutter EST600



TECHNICAL DATA	Unit	EST 600
Recommended excavator weight	t	15 - 25
Rated power	KW	80
Cutting width (B)	mm	60 - 100
Cutting depth (C)	mm	600
Torque at 350 bar	Nm	15,200
Maximum oil flow at 50 bar	l/min	210
Recommended oil flow	l/min	200
Maximum operating hydraulic pressure	bar	380
Max. size of rebar in reinforced concrete	mm	not allowed
Max. uniaxial compressive strength	MPa	60
Standard pick ¹⁾	Type	19/33/30/15

Further model EST500 + EST1000
still in development and available in 2017

NEW PRODUCTS AND DEVELOPMENTS

ETR 3 - NARROW CHAIN TRENCHER for Excavators

ETR 3

- Suitable for excavators 35 - 60 to
- Cutting width: 300 - 600 mm
- Cutting depth: 1500 - 2500 mm
- Drive power: 220 KW
- Recom. oil flow: 300-550 l/min
- Max. oil flow: 600 l/min
- Operating weight: approx. 6000 KG

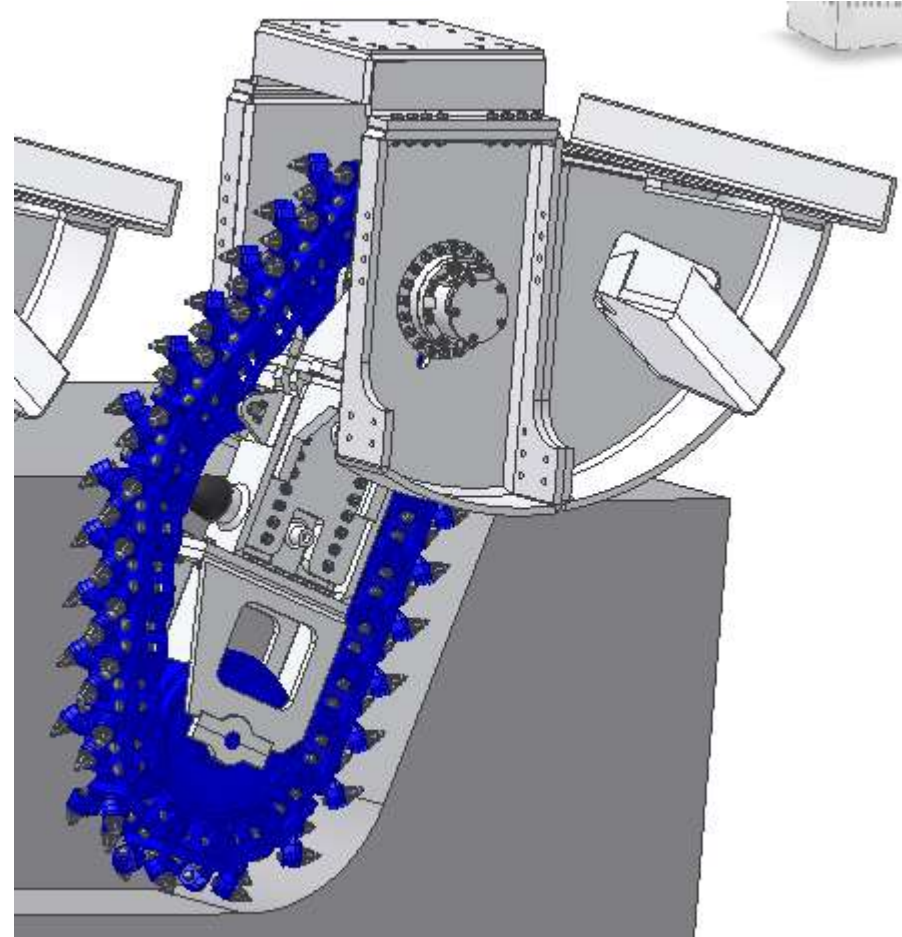
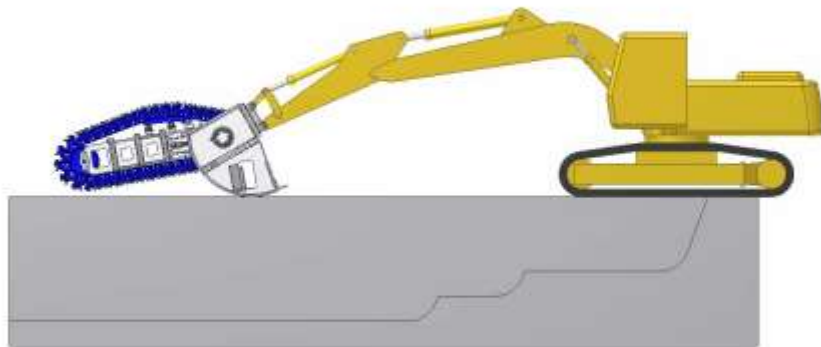

NEW PRODUCTS AND DEVELOPMENTS

ETR 600 CHAIN TRENCHER for Excavators

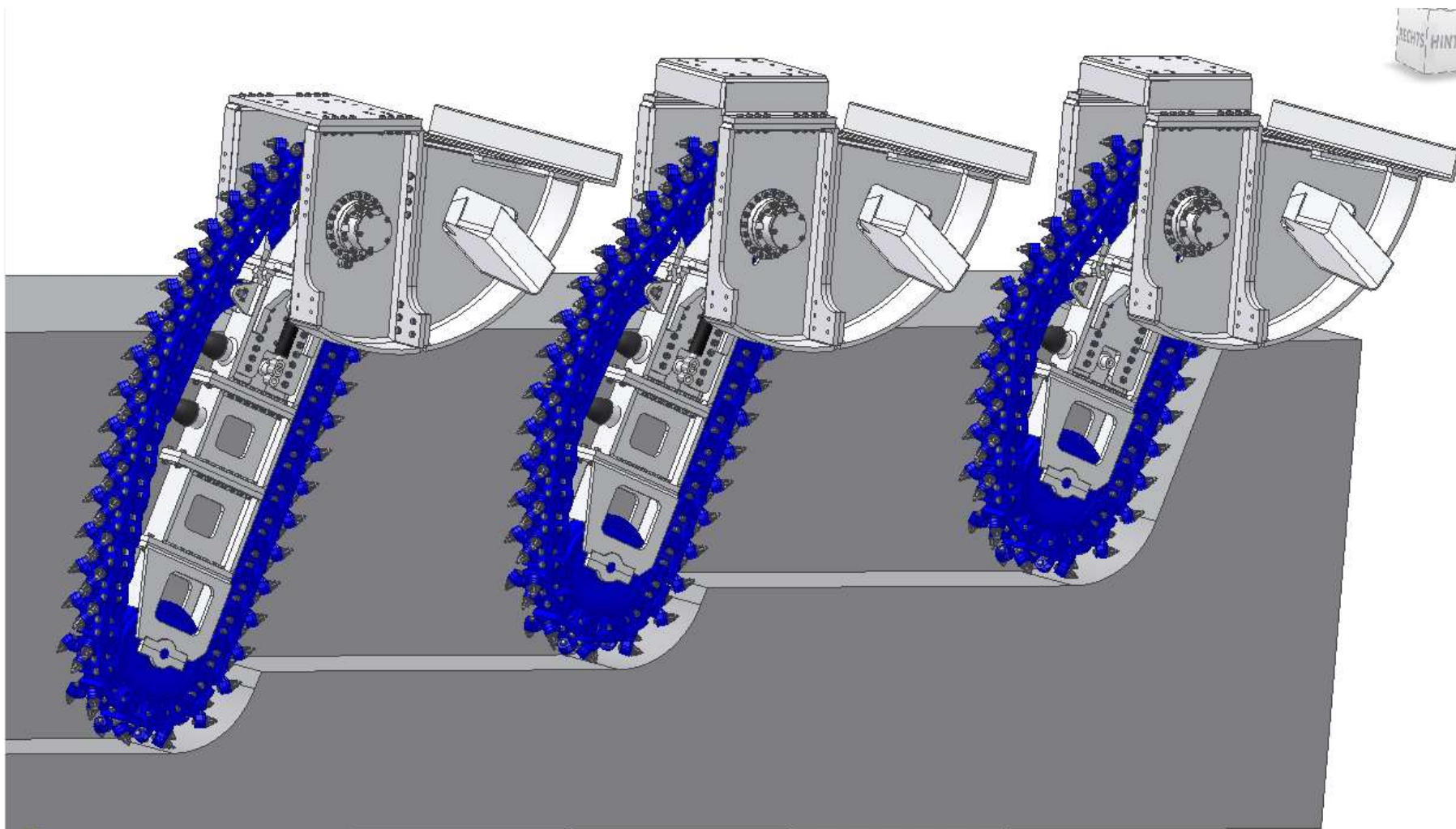

4

NEW PRODUCTS AND DEVELOPMENTS ETR 600 CHAIN TRENCHER for Excavators



NEW PRODUCTS AND DEVELOPMENTS

ERL700 and ERL1100

The longitudinal Drum Cutter ERL700 resp. ERL1100 is equipped with 160 mm hex drive shaft which allows simple change of cutting heads and use also with auger system. One basic machine for different hyd. motor sizes suitable for excavators 12 to 35 to

- ERL700 with 70 kW hydraulic motor
- ERL 1100 with 120 kW hydraulic motor

TECHNICAL DATA	Unit	NEW ERL 700	NEW ERL 1100
Recommended excavator weight	t	15 - 25	25 - 35
Rated power	kW	70	120
Length of drum cutter (A)	mm	1,230	1,230
optionale Length of drum cutter (A)	mm	-	-
Diameter of standard cutter drums (B)	mm	450	500
Length of standard cutter drum (C)	mm	450	500
Recommended rotation speed	rpm	12,700	25,400
Recommended oil flow	l/min	56,444	101,600
Maximum oil flow at 10 bar	l/min	75	75
Maximum operating hydraulic pressure	bar	170	300
Torque at 350 bar	Nm	200	320
Cutting force at 350 bar	N	380	380
Weight	kg	600	630
Number of picks	Pcs	30	30
Standard pick ⁰	Type	ER 12/45/38/22 HC	ER 17/75/70/30 Q

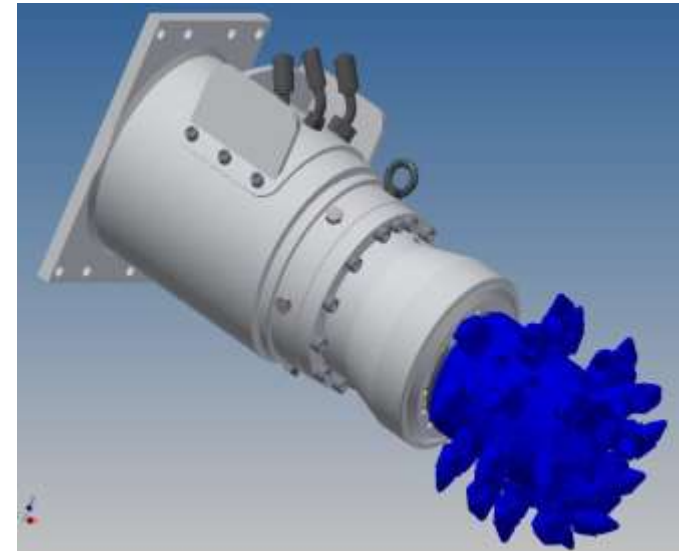

NEW PRODUCTS AND DEVELOPMENTS

ERL700 and ERL1100

The Longitudinal Drum Cutter ERL700 resp. ERL1100 is equipped with 160 mm hex drive shaft which allows simple change from standard cutter head to auger system.

ERL700 Drive unit

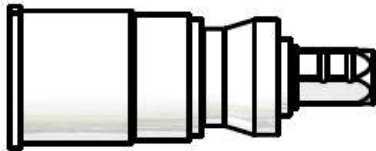

Cutting Head

Drilling Auger

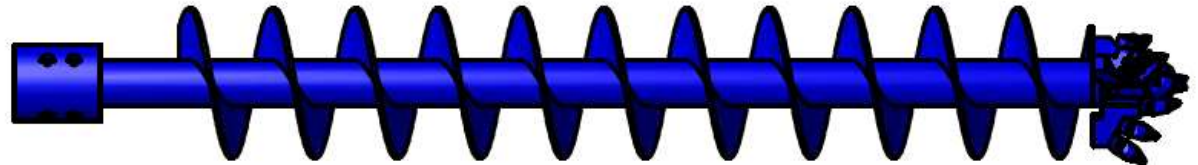

ERL 700 with Drilling Auger and Tube for Cased Drilling



NEW PRODUCTS AND DEVELOPMENTS

ERL700 and ERL1100

Longitudinal drum cutter ERL 700 for drilling holes, trenching and powerfull pile head cutting



NEW PRODUCTS AND DEVELOPMENTS

ERL700 and ERL1100

Longitudinal drum cutter ERL 700 for auger drilling of vertical holes and shafts

(principle here shown with ER600-L with drilling auger)



NEW PRODUCTS AND DEVELOPMENTS

ERL700 and ERL1100

Longitudinal drum cutter ERL 700 for cased drilling



YOUR STRONG PARTNER!

